

A0507.3.1002.C

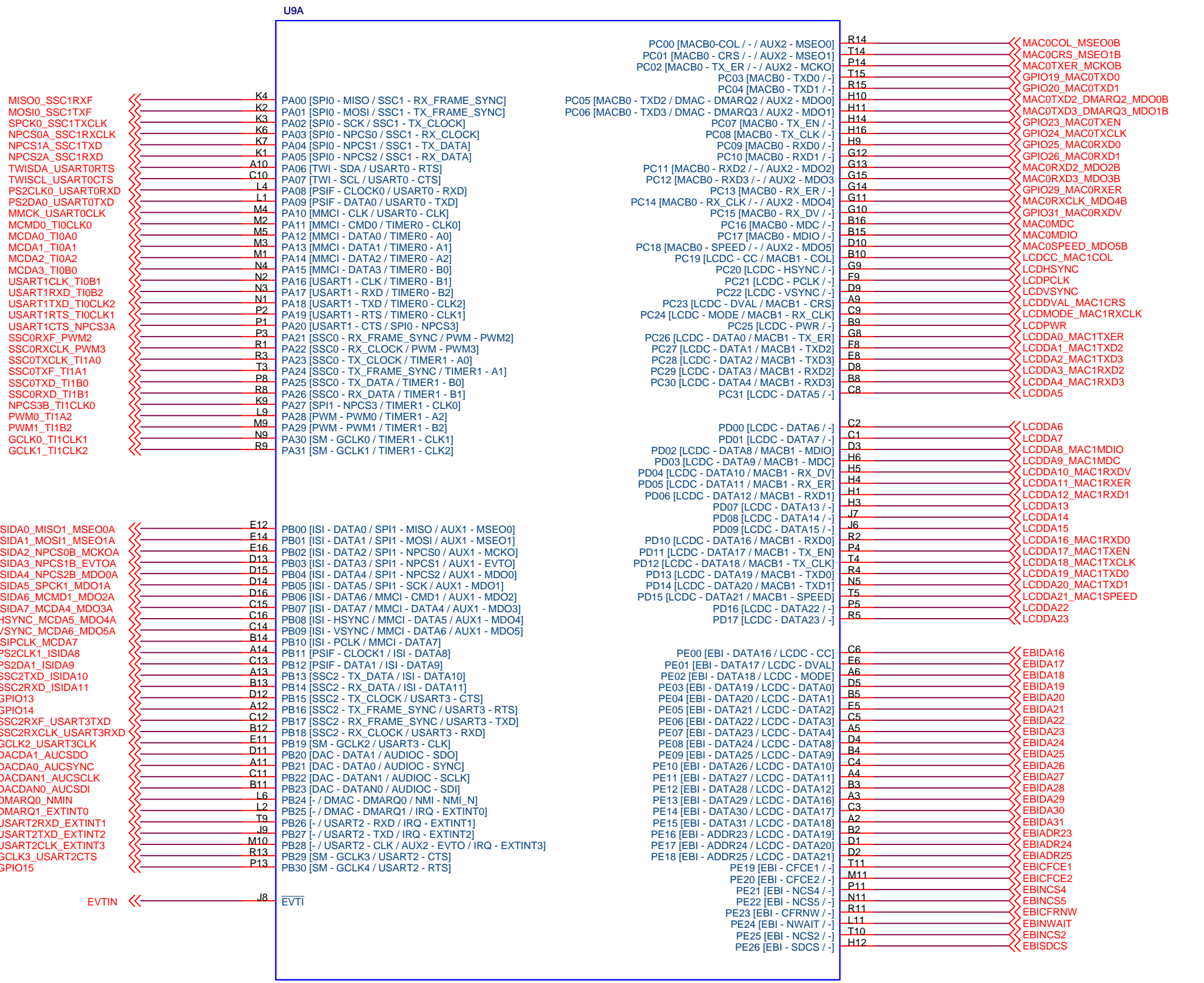

AP7000

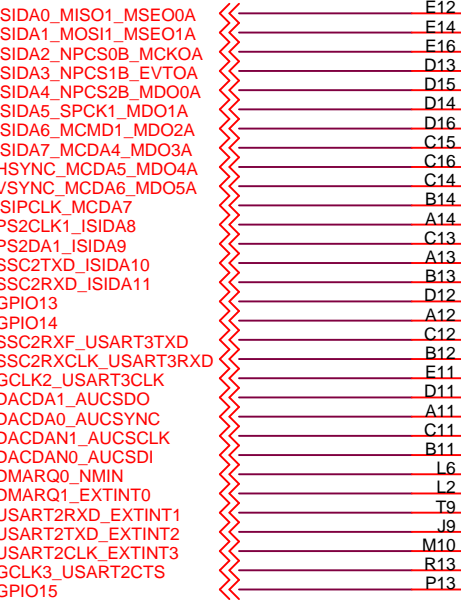

EVVIN

EVTI

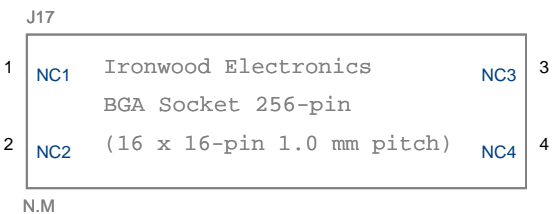

N.M

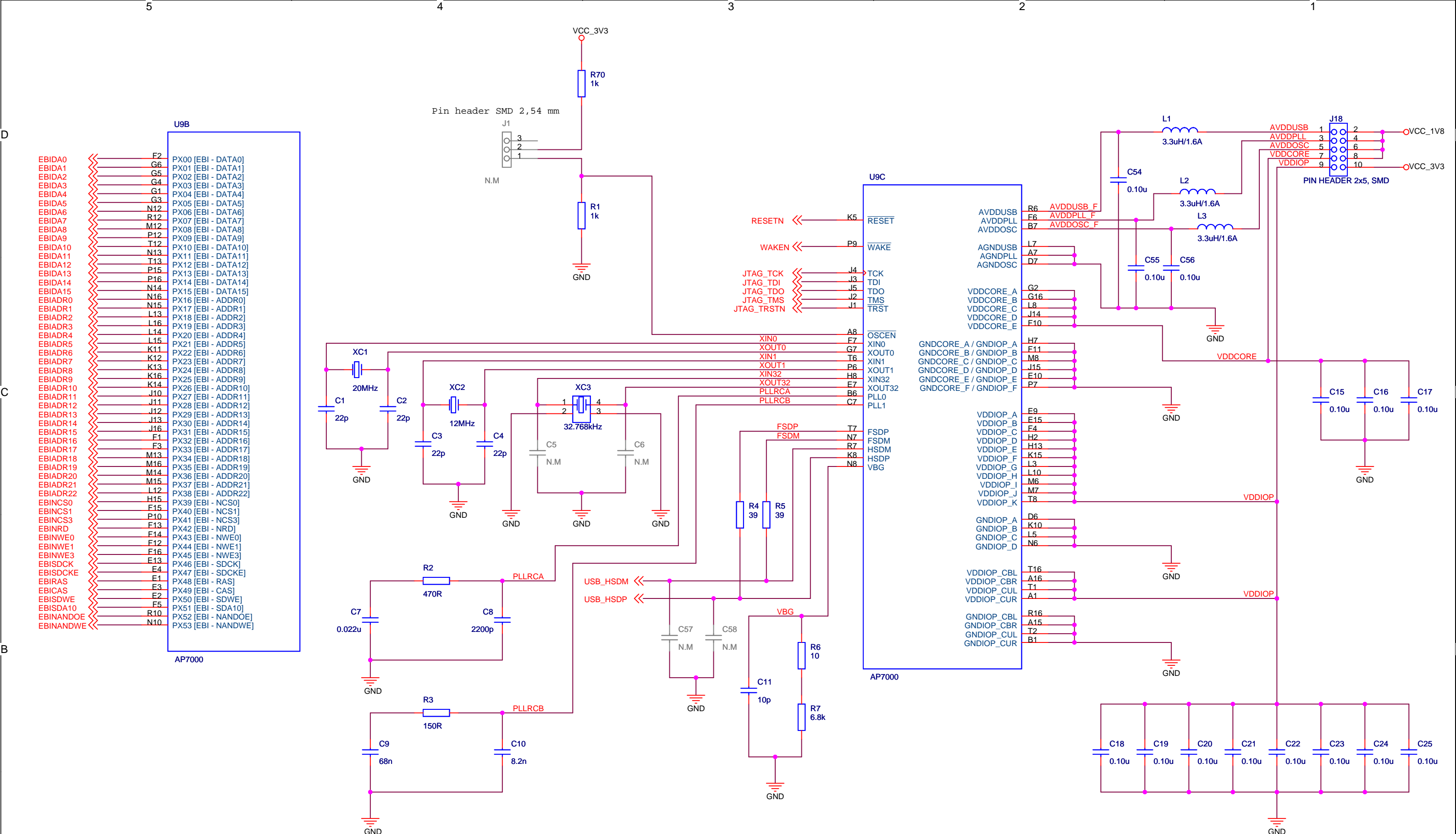

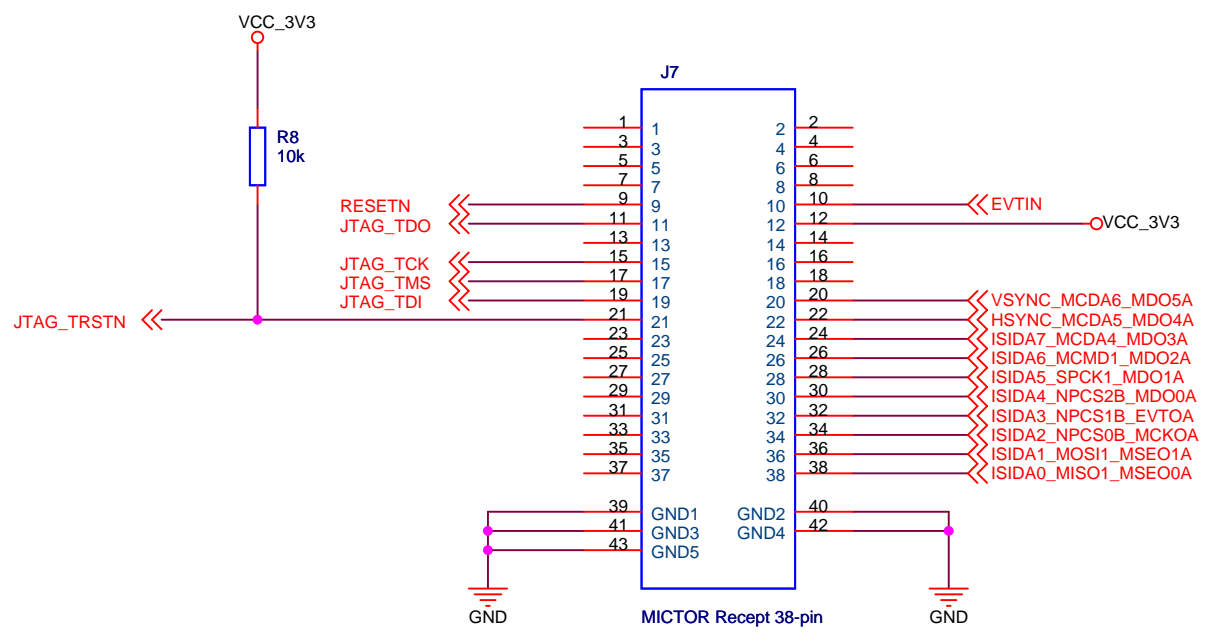
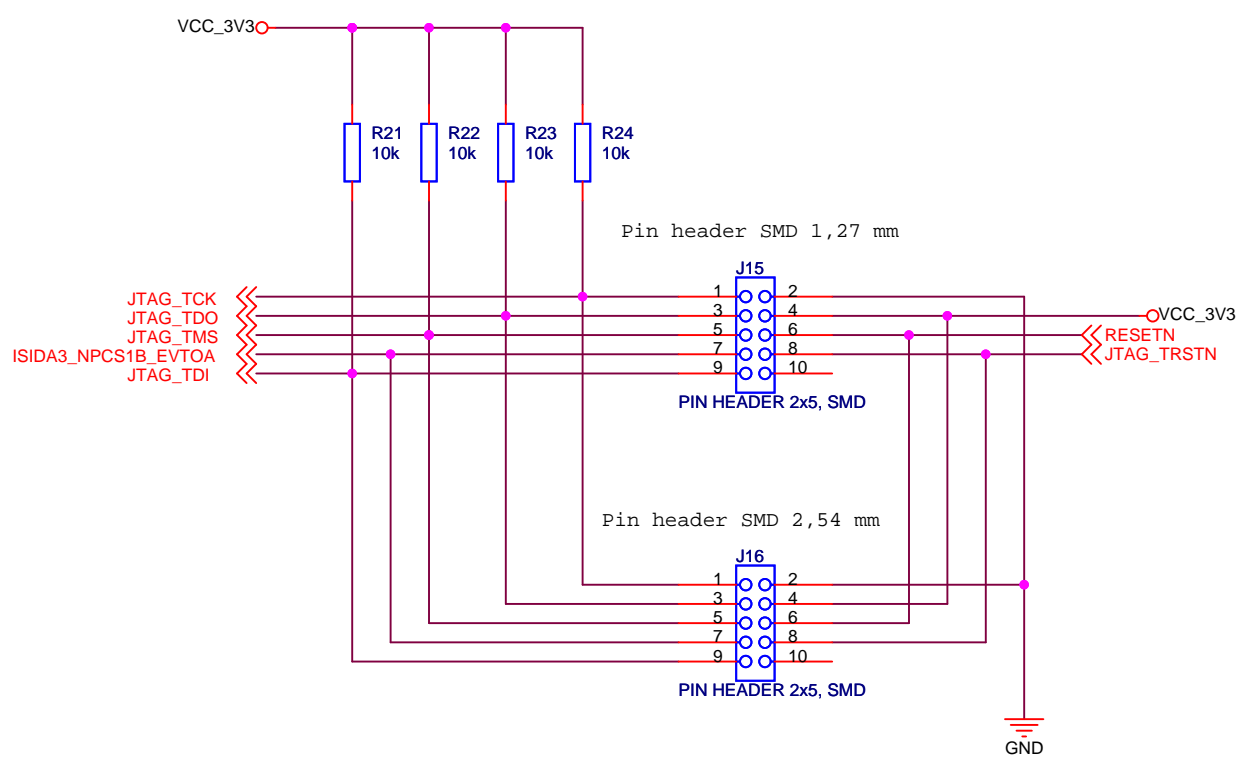

D

C

B

A



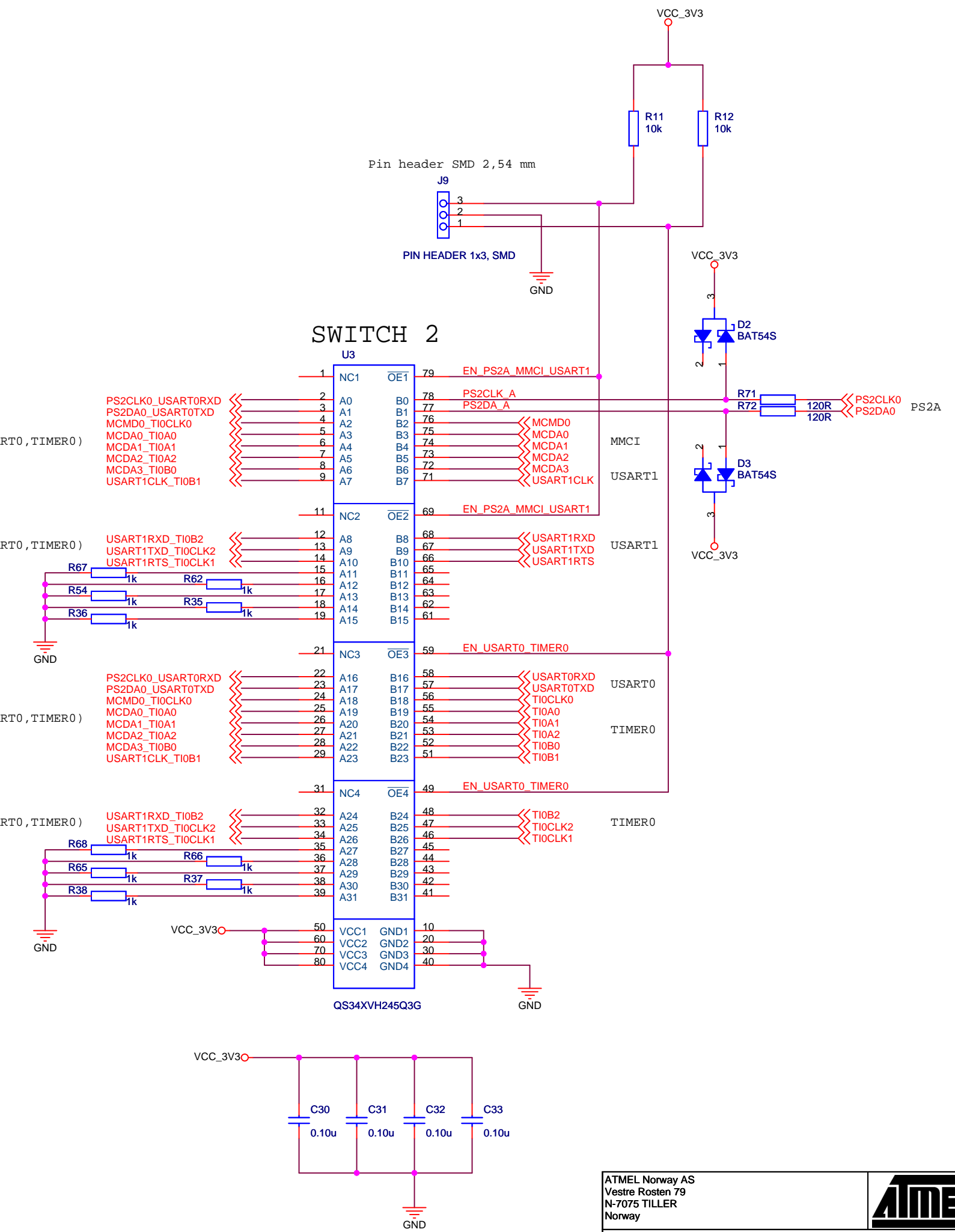
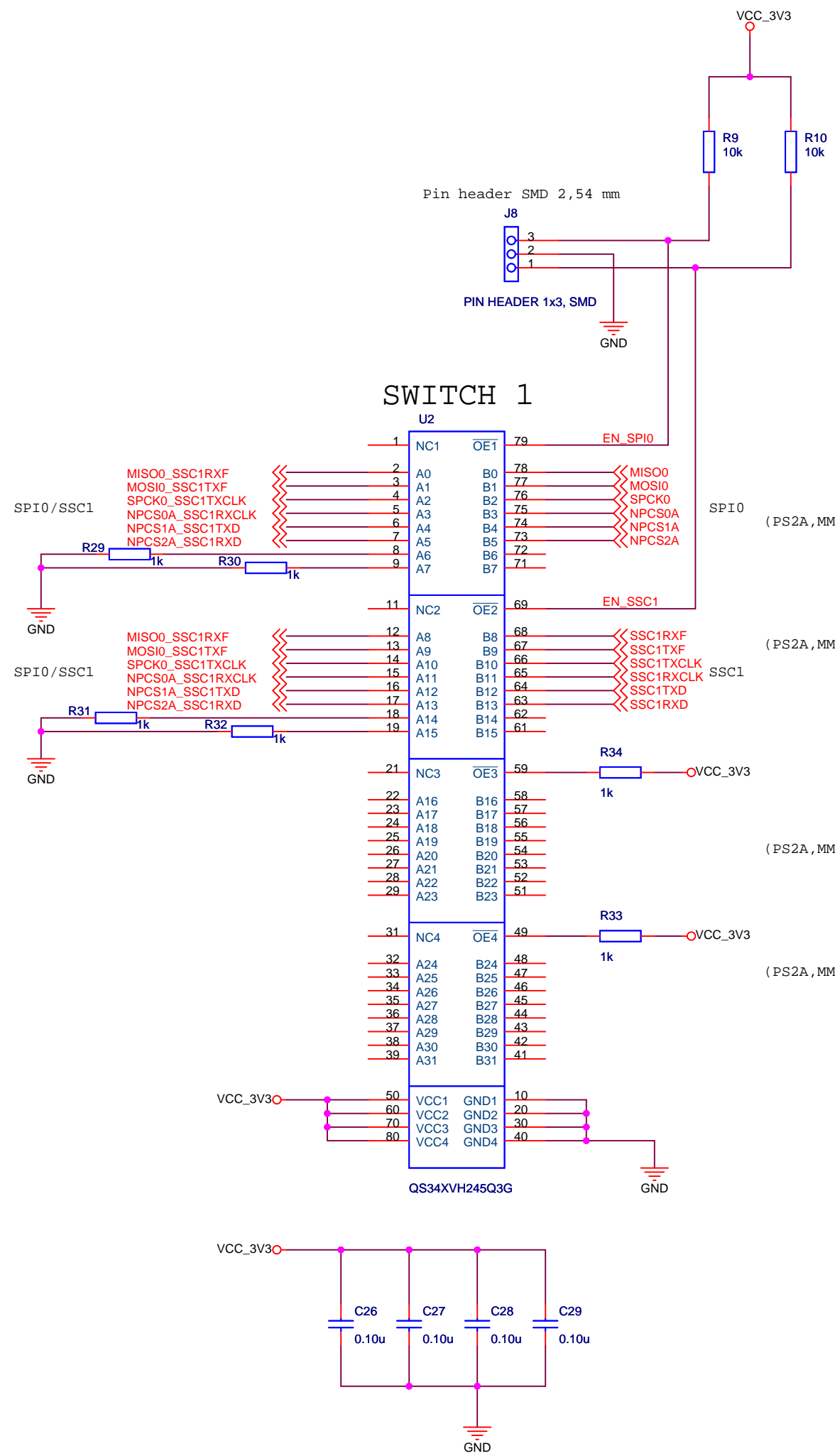

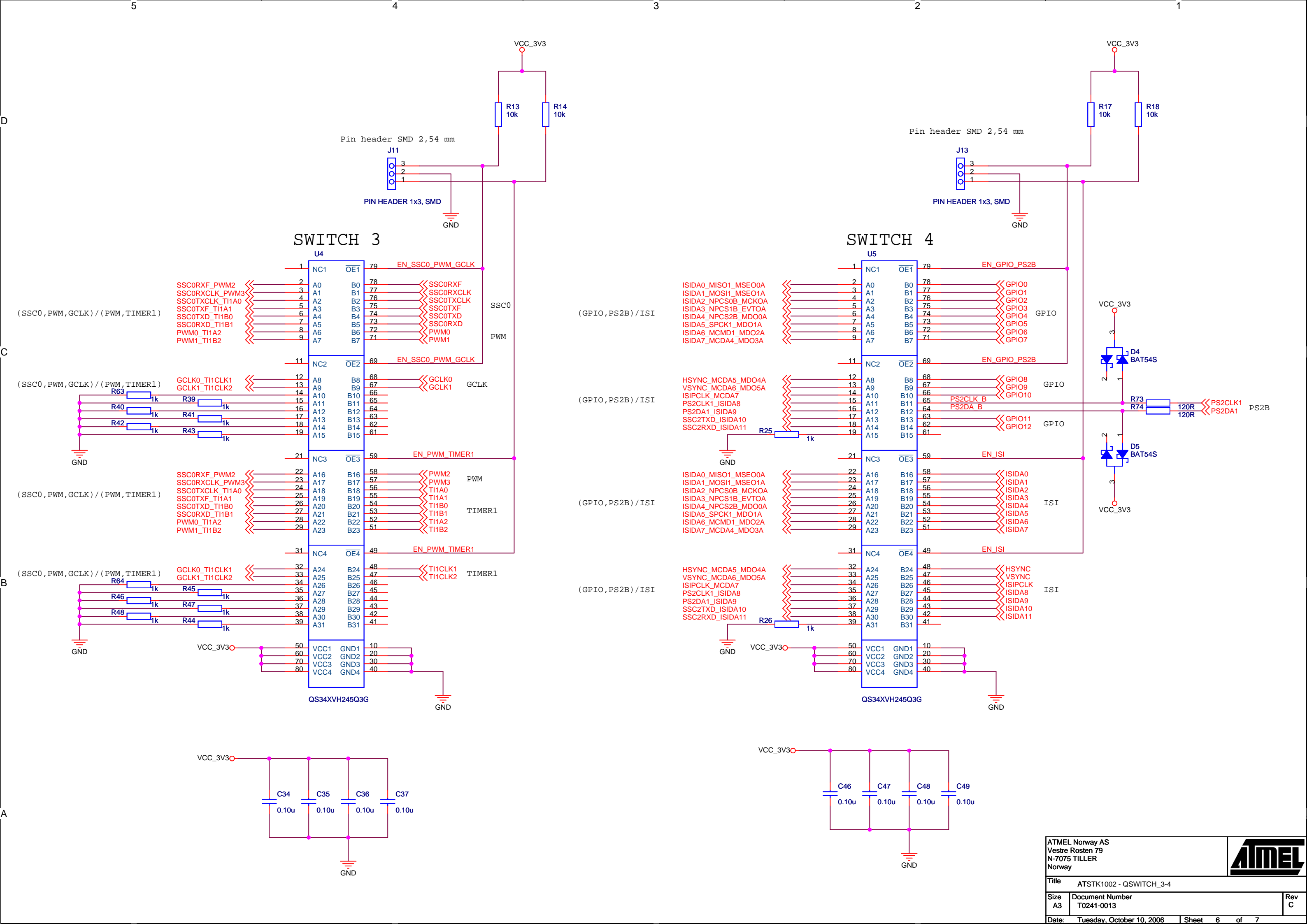

LDCDC_MAC1COL	LCDDA0_MAC1TXER
LCDDVAL_MAC1CRS	LCDDA1_MAC1TXD2
LCDMODE_MAC1RXCLK	LCDDA2_MAC1TXD3
LCDDA0_MAC1TXER	LCDDA3_MAC1RXD2
LCDDA1_MAC1TXD2	LCDDA4_MAC1RXD3
LCDDA2_MAC1TXD3	LCDDA8_MAC1MDIO
LCDDA3_MAC1RXD2	LCDDA9_MAC1MDC
LCDDA4_MAC1RXD3	LCDDA10_MAC1RXDV
LCDDA8_MAC1MDIO	LCDDA11_MAC1RXER
LCDDA9_MAC1MDC	LCDDA12_MAC1RXD1
LCDDA10_MAC1RXDV	LCDDA16_MAC1RXD0
LCDDA11_MAC1RXER	LCDDA17_MAC1TXEN
LCDDA12_MAC1RXD1	LCDDA18_MAC1TXCLK
LCDDA16_MAC1RXD0	LCDDA19_MAC1TXD0
LCDDA17_MAC1TXEN	LCDDA20_MAC1TXD1
LCDDA18_MAC1TXCLK	LCDDA21_MAC1SPEED
LCDDA19_MAC1TXD0	
LCDDA20_MAC1TXD1	
LCDDA21_MAC1SPEED	

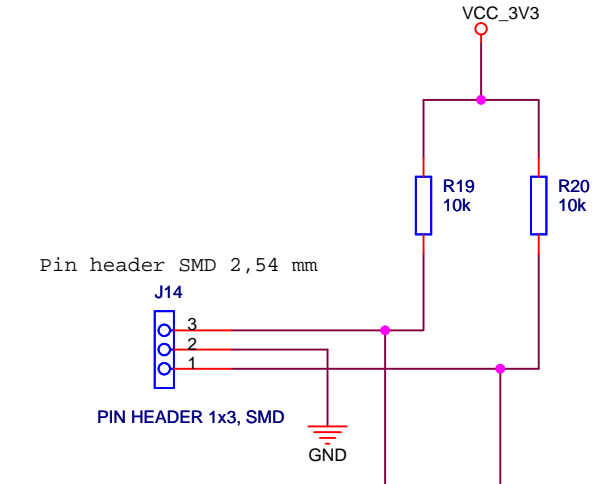
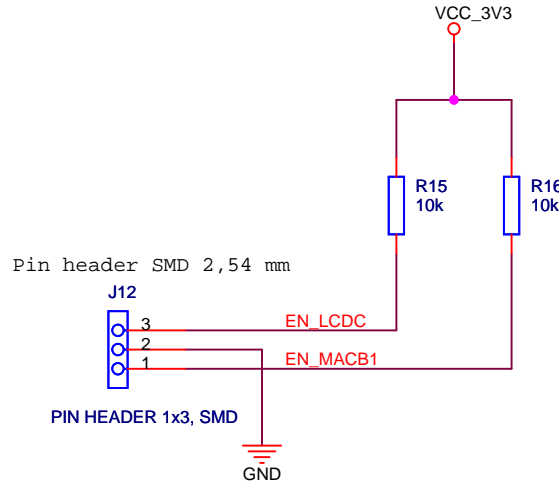

### SWITCH 5.1

### SWITCH 5.2

### SWITCH 6

