



8-bit **AVR**<sup>®</sup>  
Microcontrollers

Application Note

## AVR450: Battery Charger for SLA, NiCd, NiMH and Li-Ion Batteries

### Features

- Complete Battery Charger Design
- Modular “C” Source Code and Extremely Compact Assembly Code
- Low Cost
- Supports Most Common Battery Types
- Fast Charging Algorithm
- High Accuracy Measurement with 10-bit A/D Converter
- Optional Serial Interface
- Easy Change of Charge Parameters
- EEPROM for Storage of Battery Characteristics

### 1 Introduction

The battery charger reference design is a battery charger that fully implements the latest technology in battery charger designs. The charger can fast-charge all popular battery types without any hardware modifications. It allows a full product range of chargers to be built around a single hardware design; a new charger model is designed simply by reprogramming the desired charge algorithm into the microcontroller using In-System Programmable Flash memory. This allows minimum time to market for new products and eliminates the need to stock more than one version of the hardware. The charger design contains complete libraries for SLA, NiCd, NiMH, and Li-Ion batteries.

**Figure 1-1.** Battery Charger Reference Design Board

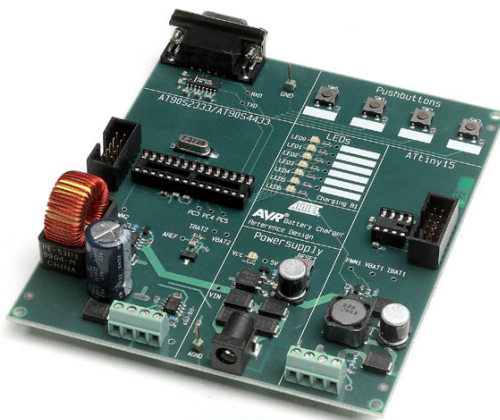

1659C-AVR-09/06





The battery charger reference design includes two battery chargers built with the high-end AT90S4433 microcontroller and the highly integrated low-cost 8-pin ATtiny15 microcontroller. However, it can be implemented using any AVR microcontroller with A/D converter, PWM output and enough program memory to store the desired charging algorithm.

As more and more electronic equipment becomes portable, the rush for better batteries with higher capacity, smaller size and lower weight will increase. The continuing improvements in battery technology calls for more sophisticated charging algorithms to ensure fast and secure charging. Higher accuracy monitoring of the charge process is required to minimize charge time and utilize maximum capacity of the battery while avoiding battery damage. The AVR® microcontrollers are one step ahead of the competition, proving perfect for the next generation of chargers.

The Atmel AVR microcontroller is the most efficient 8-bit RISC microcontroller in the market today that offers Flash, EEPROM, and 10-bits A/D converter in one chip. Flash program memory eliminates the need to stock microcontrollers with multiple software versions. Flash can be efficiently programmed in production just before shipping the finished product. Programming after mounting is made possible through fast In-System Programming (ISP), allowing up-to-date software and last minute modifications.

The EEPROM data memory can be used for storing calibration data and battery characteristics, it also allows charging history to be permanently recorded, allowing the charger to optimize for improved battery capacity. The integrated 10-bit A/D converter gives superior resolution for the battery measurements compared to other microcontroller-based solutions. Improved resolution allows charging to continue closer to the maximum capacity of the battery. Improved resolution also eliminates the need for external op-amps to “window” the voltage. The result is reduced board space and lower system cost.

AVR is the only 8-bit microcontroller designed for high-level languages like “C”. The reference design for AT90S4433 is written entirely in “C”, demonstrating the superior simplicity of software design in high-level languages. C-code makes this reference design easy to adopt and modify for today’s and tomorrow’s batteries. The reference design for ATtiny15 is written in assembly to achieve maximum code density.

## 2 Theory of Operation

The charging of a battery is made possible by a reversible chemical reaction that restores energy in a chemical system. Depending on the chemicals used, the battery will have certain characteristics. When designing a charger, a detailed knowledge of these characteristics is required to avoid damage inflicted by overcharging.

### 2.1 The AVR 8-bit RISC MCU

The reference designs includes two separate battery chargers. One using AT90S4433 AVR microcontroller and one using the ATtiny15 AVR microcontroller. The AT90S4433 design demonstrates how efficient a battery charger can be implemented with C-code. The ATtiny15 design shows the highest integrated and lowest cost battery charger available in today’s market. The AT90S4433 can be used for voltage and temperature monitoring with UART interface to PC for data logging. Table 1 shows the differences in the design.

**Table 2-1. Design Differences**

	<b>AT90S4433 Design</b>	<b>ATtiny15 Design</b>
Programming Language	C	Assembly
Code Size (approximately)	1.5K Bytes	<350 Bytes
Current Measurement	External Op-Amp Gain Stage	Built-in Differential Gain Stage
PWM Frequency	14 kHz, 8-bit Resolution	100 kHz, 8-bit Resolution
Clock Source	External Crystal, 7.3 MHz	Internal Calibrated RC Oscillator, 1.6 MHz
Serial Comm. Interface	Yes	No
In-System Programming	Yes	Yes

## 2.2 Battery Technologies

Modern consumer electronics use mainly four different types of rechargeable batteries:

- Sealed Lead Acid (SLA)
- Nickel Cadmium (NiCd)
- Nickel Metal Hydride (NiMH)
- Lithium-Ion (Li-Ion)

It is important to have some background information on these batteries to be able to select the right battery and charging algorithm for the application.

### 2.2.1 Sealed Lead Acid (SLA)

Sealed Lead Acid batteries are used in many applications where cost is more important than space and weight, typically preferred as backup batteries for UPS and alarm-systems. The SLA batteries are charged using constant voltage, with a current limiter to avoid overheating in the initial stage of the charging process. SLA batteries can be charged infinitely, as long as the cell voltage never exceeds the manufacturer specifications (typically 2.2V).

### 2.2.2 Nickel Cadmium (NiCd)

Nickel Cadmium batteries are widely used today. They are relatively cheap and convenient to use. A typical NiCd cell can be fully charged up to 1,000 times. They have a high self-discharge rate. NiCd batteries are damaged from being reversed, and the first cell to discharge completely in a battery pack will be reversed. To avoid damaging discharge of a battery pack, the voltage should be constantly monitored and the application should be shutdown when the cell voltage drops below 1.0V. NiCd batteries are charged with constant current.

### 2.2.3 Nickel Metal Hydride (NiMH)

Nickel Metal Hydride batteries are the most widely used battery type in new lightweight portable applications (i.e., cell phones, camcorders, etc.). They have a higher energy density than NiCd. NiMH batteries are damaged from overcharging. It is therefore important to do accurate measurements to terminate the charging at exactly the right time (i.e., fully charge the battery without overcharging). Like NiCd, NiMH batteries are damaged from being reversed.





NiMH has a self-discharge rate of approximately 20%/ month. Like NiCd batteries, NiMH batteries are charged with constant current.

#### 2.2.4 Lithium-Ion (Li-Ion)

Lithium-Ion batteries have the highest energy/weight and energy/space ratio compared to the other batteries in this application note. Li-Ion batteries are charged using constant voltage, with current limiter to avoid overheating in the initial stage of the charging process. The charging is terminated when the charging current drops below the lower current limit set by the manufacturer. The battery takes damage from overcharging and may explode when overcharged.

### 2.3 Safe Charging of Batteries

Modern fast chargers (i.e., battery fully charged in less than three hours, normally one hour) requires accurate measurements of the cell voltage, charging current and battery temperature in order to fully charge the battery completely without overcharging or otherwise damage it.

#### 2.3.1 Charge Methods

SLA and Li-Ion batteries are charged with constant voltage (current limited). NiCd and NiMH batteries are charged with constant current and have a set of different termination methods.

#### 2.3.2 Maximum Charge Current

The maximum charge current is dependent on the battery capacity (C). The maximum charge current is normally given in amounts of the battery capacity. For example, a battery with a cell capacity of 750 mAh charged with a charging current of 750 mA is referred to as being charged at 1C (1 times the battery capacity). If the charging current for trickle-charge is set to be C/40 the charging current is the cell capacity divided by 40.

#### 2.3.3 Overheating

By transferring electric energy into a battery, the battery is charged. This energy is stored in a chemical process. But not all the electrical energy applied to the battery is transformed into the battery as chemical energy. Some of the electrical energy ends up as thermal energy, heating up the battery. When the battery is fully charged, all the electrical energy applied to the battery ends up as thermal energy. On a fast charger, this will rapidly heat up the battery, inflicting damage to the battery if the charging is not terminated. Monitoring the temperature to terminate the charging is an important factor in designing a good battery charger.

### 2.4 Termination Methods

The application and environment where the battery is used sets limitations on the choice of termination method. Sometimes it might be impractical to measure the temperature of the battery and easier to measure the voltage, or the other way around. This reference design implements the use of voltage drop (-dV/dt) as primary termination method, with temperature and absolute voltage as backup. But the hardware supports all of the below mentioned methods.

**2.4.1 t – Time**

This is one of the simplest ways to measure when to terminate the charging. Normally used as backup termination when fast-charging. Also used as primary termination method in normal charging (14 - 16h). Applies to all batteries.

**2.4.2 V – Voltage**

Charging is terminated when the voltage rises above a preset upper limit. Used in combination with constant current charging. Maximum current is determined by the battery, usually 1C as described above. Current limiting is crucial to avoid thermal damage to the battery if charge current is too high. SLA batteries are normally charged infinitely by setting the maximum voltage above the actual charge voltage. Used for Li-Ion as primary charging algorithm/termination method. Li-Ion chargers usually continue with a second phase after the maximum voltage has been reached to safely charge the battery to 100%. Also used on NiCd and NiMH as backup termination.

**2.4.3 -dV/dt – Voltage Drop**

This termination method utilizes the negative derivative of voltage over time, monitoring the voltage drop occurring in some battery types if charging is continued after the battery is fully charged. Commonly used with constant current charging. Applies to fast-charging of NiCd and NiMH batteries.

**2.4.4 I – Current**

Charging is terminated when the charge current drops below a preset value. Commonly used with constant voltage charging. Applies to SLA and Li-Ion to terminate the top-off charge phase usually following the fast-charge phase.

**2.4.5 T – Temperature**

Absolute temperature can be used as termination (for NiCd and NiMH batteries), but is preferred as backup termination method only. Charging of all batteries should be terminated if the temperature rises above the operating temperature limit set by the manufacturer. Also used as a backup method to abort charging if voltage drops below a safe temperature – Applies to all batteries.

**2.4.6 dT/dt – Temperature Rise**

The derivative of temperature over time can be used as termination method when fast-charging. Refer to the manufacturer's specifications on information on the exact termination point (Typically 1C/min for NiCd batteries) – Applies to NiCd and NiMH.

**2.4.7 DT – Temperature over Ambient Temperature**

Terminates charging when the difference between ambient (room) temperature and battery temperature rises over a preset threshold level. Applies to NiCd and SLA as primary or backup termination method. Preferred over absolute temperature to avoid battery damage when charged in a cold environment. As most systems have only one temperature probe available, the ambient temperature is usually measured before charging is initiated.

### 2.4.8 $dV/dt = 0$ – Zero Delta Voltage

This termination method is very similar to the  $-dV/dt$  method, but pinpoints more accurately when the time voltage no longer rises. Applies to NiCd and NiMH batteries.

## 3 Hardware Implementation

The reference design includes two complete battery charger designs. The reference design is divided in 5 main blocks (see Figure 3-1).

**Figure 3-1.** The Main Blocks of the Battery Charger Reference Design

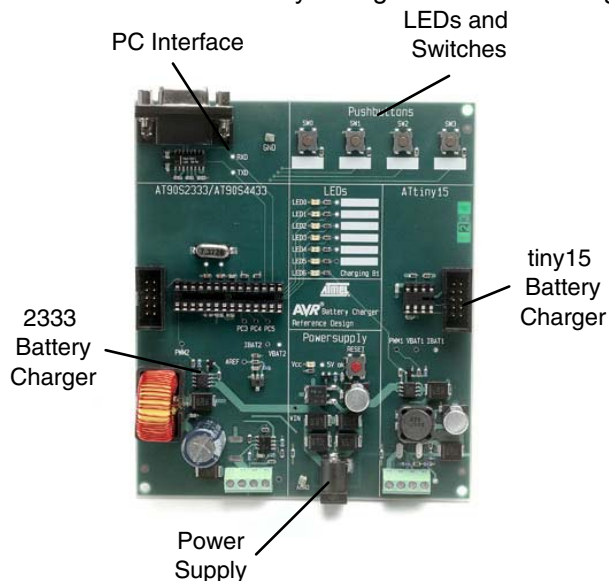

### 3.1.1 Power Supply

Includes analog reference, push-button and LEDs. The input voltage is rectified through D9 - D12 and then filtered by C13. The rectified input voltage can be measured at the testpoint marked “ $V_{IN}$ ”.  $V_{IN}$  is supplied to both the buck converter and to the LM7805 voltage regulator. The LM7805 delivers 5V for the microcontrollers. This voltage can be measured at the testpoint marked “ $V_{CC}$ ” The LED marked “5V OK” indicates power on.

### 3.1.2 PC Interface

Connected to the UART interface on the AT90S4433. Can be used to interface PC for logging battery data during charging. The data can be imported in a spreadsheet to display the charging characteristic for a battery. The AT90S4433 can also be used as data logger when using the ATtiny15 battery charger.

### 3.1.3 LEDs and Switches

The board has several LEDs and switches for debug/monitoring purpose. Only few are used in the current applications, but the rest can be added easily when need.

- LED0: Connected to Port B, pin 0 on AT90S4433. Used in the current application for visualizing the charge mode fast or trickle.
- LED1: Connected to Port B, pin 2 on AT90S4433.

- LED2: Connected to Port B, pin 3 on AT90S4433.
- LED3: Connected to Port B, pin 0 on the AT90S4433. Used to display “Error” in the AT90S4433 application.
- LED4: Not connected, can be connected to test points on the board for extended debug/monitoring.
- LED5: Not connected, can be connected to test points on the board for extended debug/monitoring.
- LED6: Connected to Port B, pin 1 on ATtiny15. Used In the current application for visualizing the PWM frequency.
- VCCPower: Indicates power status.
- SW0: Connected to Port D, pin 4 on AT90S4433. Used to start the charger in the current AT90S4433 application.
- SW1: Connected to Port D, pin 5 on AT90S4433.
- SW2: Connected to Port D, pin 6 on AT90S4433.
- SW3: Connected to Port D, pin 7 on AT90S4433.
- RESET: Restarts the program and is used to recover from charge errors.

### 3.1.4 In-System Programming (ISP) Interface

Both designs have a 10-pin ISP header on the test board. The Flash program memory and EEPROM data memory can be downloaded from AVRISP PC programming software.

### 3.1.5 ATtiny15 with 100 kHz Buck Converter

ATtiny15 includes special features to make it specially suited for battery charger applications. The internal 100 kHz PWM is connected to a buck converter. The high switching frequency and high accuracy reduce the size of the external coil and capacitors. Testpoints are added to easily monitor the PWM output, voltage input, and current input. The ATtiny15 includes an internal gain stage that can amplify the differential voltage between two A/D channels. This eliminates the need for external op-amps. The charge current is measured as the differential between two A/D channels over a 0.25Ω resistor. Power supply for the battery charger is shown in Appendix 2.

### 3.1.6 AT90S4433 with 14 kHz Buck Converter

The 90S4433 battery charger design uses an external op-amps to amplify the voltage for the current measurement. This ensures the highest accuracy for the battery measurement. The charger is capable of communicating with a PC, which can be used to monitor charging parameters and to debug the charging algorithm.

The battery charger circuit was designed to charge any of the four battery types SLA, NiCd, NiMH and Li-Ion with the appropriate charge algorithm. These charge algorithms include fast-charge mode and a top-off trickle-charge to gain minimum charge time with maximum battery capacity. Power supply for the battery charger is shown in Appendix 2.

### 3.1.7 Buck Converter

The buck-converter is similar for both the AT90S4433 and the ATtiny15. They consist of one P-channel MOSFET switching transistor driven by the AVR via one bipolar NPN transistor. The switching transistor is connected to an inductor, a diode and a



capacitor (see Figure 3-2). An additional diode prevents the battery from supplying voltage into the microcontroller when the power is disconnected. When the switching transistor is on (illustrated by a switch on the figures below) the current will flow like Figure 3-2A illustrates. The capacitor is charged from the input via the inductor (the inductor is also charged up). When the switch is opened (Figure 3-2B), the inductor will try to maintain its current-flow by inducing a voltage. The current flows through the diode and the inductor will charge the capacitor. Then the cycle repeats itself. If the duty cycle is decreased, by shorter on time, longer off time, the voltage will decrease. If the duty cycle is increased (longer on timer, shorter off time), the voltage will increase. The buck-converter is most efficient running on a duty cycle of 50%.

**Figure 3-2.** Buck Converter Switching Principle



### 3.1.8 Voltage Reference

The voltage reference is supplied by a TL431 CPK voltage reference.  $A_{REF}$  is set by the resistors  $R_{34}$  and  $R_{10}$  and can be calculated by:

$$A_{REF} = V_{REF} \cdot \left( 1 + \frac{R_{34}}{R_{10}} \right) = 2.495 \cdot \left( 1 + \frac{4K7}{10K} \right) = 3.67V$$

This value is a trade-off between a high-resolution (low  $A_{REF}$  value) and a high signal-to-noise ratio (high  $A_{REF}$  value). The voltage reference is common for both battery charger designs

### 3.1.9 Battery Temperature

Temperature is measured by a negative temperature coefficient (NTC) resistor. It has an approximate resistance of 10 k $\Omega$  at 25°C. The NTC is part of a voltage divider, which is powered by the reference voltage.

The resolution in respect to the voltage measured across the NTC is the same as for the voltage measurement circuit.

Resolution:

$$\frac{3.67V}{1024 \text{ steps}} = 3.58 \frac{mV}{\text{step}}$$

The steps can be calculated by the following equation:

$$N = 1024 \cdot \frac{R_{NTC}}{R_{NTC} + 10k\Omega}$$

The NTC resistance does not follow a linear curve, which makes it difficult to calculate the temperature from the ADC value. Using a table to look up the temperature solves this (see Table 2-1). The table indicates the steps equal to 0.5°C for ADC values 400

to 675. ADC value 400 is approximately 37°C and 675 is 8.6°C. Using this table and doing some minor changes in the header file B\_DEF.H will make it easy to implement any NTC resistor. The ATtiny15 battery charger design assumes that the linearity of the thermistor is sufficient to detect a temperature increase. Therefore, it uses a constant compare value to monitor the temperature.

The values in the table are calculated from the voltage divider at the NTC and datasheet for the NTC.

**Table 3-1. NTC Steps According to Temperature**

ADC Reading	Temperature (°C)	0.5°C Steps	NTC (Ω) Resistance
675	8.6	5	19341
650	11	4	17380
625	14	6	15664
600	16	5	14151
575	18.8	5	12806
550	21.2	5	11603
525	23.6	5	10521
500	26.2	5	9542
475	28.8	4	8652
450	32	6	7840
425	34	4	7095
400	37	5	6410
375	39.4	5	5778

## 3.2 AT90S4433 Battery Charger

This section describes theory specific for the battery charger design based on AT90S4433.

### 3.2.1 Parameters for Layout

Oscillator frequency:  $f_{OSC} = 7.3728 \text{ MHz}$

Saturation voltage:  $V_{sat} = 0.5V$

Input voltage:  $V_I = 15V$

Output voltage:  $V_O = 1.5V$

Maximum output current:  $I_{O,max} = 1.5A$

8-bit PWM:

$$T = \frac{510}{f_{osc}} = 69.173 \mu s$$

With duty cycle of 50%:

$$t_{on} = \frac{69.173 \mu s}{2} = 34.59 \mu s$$



Inductance:

$$L = \frac{(V_I - V_{sat} - V_O) \cdot t_{on}}{2 \cdot I_{O,max}} = \frac{(15V - 0.5V - 1.5V) \cdot 34.59\mu s}{2 \cdot 1.5A} = 149.9\mu H$$

$$t_{on} = \frac{L \cdot 2 \cdot I_{O,max}}{V_I - V_{sat} - V_O} = \frac{149.9\mu H \cdot 3A}{15V - 0.5V - 1.5V} = 34.59\mu s$$

This gives a duty cycle of

$$\frac{t_{on}}{T} = \frac{34.59\mu s}{69.173\mu s} = 0.50 = 50\%$$

### 3.3 AT90S4433 Measurement Circuitry

#### 3.3.1 Battery Voltage

The charging voltage is monitored using an op-amp to measure the voltage difference between the positive and the negative pole of the battery. In order to select a suitable measurement range for the charger, decide how many battery cells and what type of batteries to charge, select a suitable input voltage ( $V_1 - V_2$ ) and scale resistors for the voltage measurement. The op-amp circuit for measuring the battery voltage is an ordinary differential op-amp circuit. The equation for the output voltage from the op-amp circuit is shown below. The ADC is capable of measuring the voltage range from  $A_{GND}$  to  $A_{REF}$  (3.67V). The output voltage ( $V_{BAT2}$ ) from the op-amp has to be within this range:

$$V_{BAT2} = \frac{Ra}{Rb} \cdot (V_1 - V_2)$$

Where:

- $V_{BAT2}$  is the output voltage from the op-amp to the AVR A/D.
- $V_1$  is the positive pole of the battery.
- $V_2$  is the negative pole of the battery.
- $R_a$  and  $R_b$  are the resistors in the resistor network used to set the gain for the op-amp.
- $R_a$  is equal to  $R_{10}$  and  $R_{12}$ .
- $R_b$  is equal to  $R_6$  and  $R_7$ .

The maximum charge voltage will be:

$$(V_1 - V_2) = \frac{Ra}{Rb} \cdot A_{REF} = \frac{33k\Omega}{10k\Omega} \cdot 3.67V = 12.1V$$

Gain in op-amp:

$$G_{U1B} = \frac{Ra}{Rb} = \frac{10k\Omega}{33k\Omega} = 0.303$$

The resulting battery measurement resolution:

$$\frac{ADC_{resolution}}{G_{U1B}} = \frac{3.58mV}{0.303} = 11.82 \frac{mV}{step}$$

### 3.3.2 Charge Current

The charge current is measured by sensing the voltage over a 0.033Ω shunt-resistor( $R_1$ ). This voltage is amplified using an op-amp to improve the accuracy of the measurement before it is fed into the A/D converter.

This voltage is amplified by the factor:

$$1 + \frac{R_5}{R_2} = 1 + \frac{39k\Omega}{680k\Omega} = 58.4$$

The op-amp output voltage is therefore:

$$V_{ibat2} = \left(1 + \frac{R_5}{R_2}\right) \cdot I_{Shunt} \cdot R_6$$

which is:

$$V_{ibat2} = 1.926 \cdot I_{Shunt}$$

The maximum current that can be measured is:

$$I_{BAT_{MAX}} = \frac{3.58}{1.926} = 2.0A$$

This gives a resolution of:

$$\frac{200mA}{1024steps} = 1.95 \frac{mA}{step}$$

The step number for a given current can now be calculated from:

$$N = \frac{I_{Shunt}}{1.95 \frac{mA}{step}}$$

The current from a certain step number is:

$$I_{Shunt} = N \cdot 1.95 \frac{mA}{step}$$

### 3.4 ATtiny15 Battery Charger

This section describes theory specific for the battery charger design based on ATtiny15. The 25.6 MHz oscillator frequency is generated with an on-chip PLL from an 1.6 MHz internal RC-oscillator. The reference design is shipped without resistors for dividing down the voltage of the battery. This limits the maximum voltage to 3.67V, making it suitable for 1-2 cells NiCd or NiMh batteries. To use higher voltages, simply add the required resistors to divide down the voltage into the 0-3.67V range. Calculation of the resistors are described at the end of this section.

#### 3.4.1 Parameters for Layout

Oscillator frequency:	$f_{OSC}$	= 25.6 MHz
Saturation voltage:	$V_{sat}$	= 0.5V
Input voltage:	$V_I$	= 12V
Output voltage:	$V_O$	= 1.5V
Maximum output current:	$I_{O,max}$	= 1.5A

8-bit PWM:

$$T = \frac{255}{f_{OSC}} = 9.96 \mu s$$

With duty cycle of 50%:

$$t_{on} = \frac{9.96 \mu s}{2} = 4.98 \mu s$$

Inductance:

$$L = \frac{(V_I - V_{sat} - V_O) \cdot t_{on}}{2 \cdot I_{O,max}} = \frac{(15V - 0.5V - 1.5V) \cdot 4.98 \mu s}{2 \cdot 1.5A} = 21.58 \mu H$$

$$t_{on} = \frac{L \cdot 2 \cdot I_{O,max}}{V_I - V_{sat} - V_O} = \frac{21.58 \mu H \cdot 3A}{15V - 0.5V - 1.5V} = 4.98 \mu s$$

This gives a duty cycle of

$$\frac{t_{on}}{T} = \frac{4.98 \mu s}{9.96 \mu s} = 0.50 = 50\%$$

### 3.5 ATtiny15 Measurement Circuitry

#### 3.5.1 Battery Voltage

The charge voltage is measured directly on the positive battery pole. When a voltage higher than the reference voltage (3.67V) is used to charge the battery, the charging voltage can be divided down with two resistors to fit into the 0-3.67V area. This input is also the negative input for the differential measurement of the battery charge current as shown in Figure 4. The current is measured as the difference between the negative and positive input to the internal 20x gain stage. This voltage is measured over a 0.25Ω shunt resistor.

All measurements are done with 10-bit (1024 steps) resolution.

**Figure 3-3. Voltage and Current Measurement**

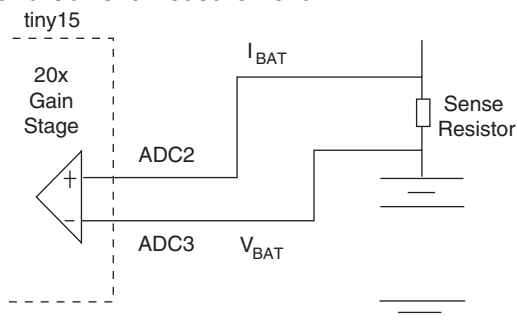

The voltage resolution is decided by  $A_{REF}$ .

Resolution:

In order to select a suitable measurement range for the charger, decide how many battery cells and what type of batteries to charge. The ADC is capable of measuring the voltage range from AGND to AREF (3.67V). The output voltage ( $V_{ADC}$ ) from the voltage divider has to be within this range:

$$V_{ADC} = \frac{R_b}{R_a + R_b} \cdot V_b$$

Where:

- $V_{ADC}$  is the output voltage from the voltage divider to the AVR A/D.
- $V_b$  is the battery voltage.
- $R_a$  and  $R_b$  are the resistors used to scale down the battery voltage.
- $R_a$  is equal to  $R_8$  in the reference design.
- $R_b$  is equal to  $R_{16}$  in the reference design

Note that the resistors  $R_9$  and  $R_{17}$  for scaling down the voltage of the shunt resistors must be equal to  $R_8$  and  $R_{16}$  for scaling down the voltage measurement. The reference design uses  $R_8 = R_9 = 3.7 \text{ k}\Omega$  and  $R_{16} = R_{17} = 2.2 \text{ k}\Omega$ .

This gives maximum charge voltage:

$$V_{bat} = \left(1 + \frac{R_8}{R_{16}}\right) \cdot V_{ADC} = \left(1 + \frac{3.7 \text{ k}\Omega}{2.2 \text{ k}\Omega}\right) \cdot 3.67 \text{ V} = 9.8 \text{ V}$$

## 3.5.2 Charge Current

The charge current is measured by sensing the voltage over 0.025W shunt-resistor. This voltage is amplified 20 times using the internal gain stage to improve the accuracy of the measurement before it is fed into the A/D converter.

The ADC input voltage output voltage is:

$$V_{ibat} = 20 \cdot \left(\frac{R_b}{R_b + R_a}\right) \cdot I_{shunt} \cdot R_{18}$$

where:

- $V_{ibat}$  is the analog input voltage to the A/D converter.
- $I_{shunt}$  is the current through the 0.25W shunt resistor.



- Ra and Rb are the resistors used to scale down the voltage on the shunt resistor with the same scale as the voltage measurement.
- Ra is equal to R<sub>9</sub>.
- Rb is equal to R<sub>17</sub>

$$V_{ibat} = 1.864 \cdot I_{Shunt}$$

The maximum current that can be measured is:

$$I_{Shunt\ MAX} = \frac{3.67}{1.864} = 1.96A$$

This gives a resolution of:

$$\frac{1968mA}{1024steps} = 1.92 \frac{mA}{step}$$

The step number for a given current can now be calculated from:

$$N = \frac{I_{BAT}}{1.92 \frac{mA}{step}}$$

The current from a certain step number is:

$$I_{BATi} = N \cdot 1.92 \frac{mA}{step}$$

## 4 Software Implementation

This section describes the software used in the battery charger reference design, it explains the C-code implementation for AT90S4433. The same principles also applies for the assembly code for ATtiny15. For complete description of the ATtiny15 assembly code, see the comments in the source code.

The battery type to be charged has to be set at program compile time.

The software can be extended to support charging of more than one battery. The straightforward implementation is to charge batteries sequentially allowing each battery a timeslot during trickle-charge. SLA and Li-Ion batteries can be charged in parallel with constant voltage charging if the number of battery cells in each battery-pack is the same. The charging current for each battery is limited and the charging voltage is limited as for one cell.

In the "Battery Characteristics" (b\_car.h) all values are calculated with all their scaling factors. These values are defined in the include files, calculated at compile time and then handled as constants during program execution. All values taken from the A/D converter can directly be compared to these constants. This means that no time is used on recalculating values during program execution, saving time and memory

space. The values and formulas used to calculate the values are extracted from the "Measurement Circuitry" section. See "AT90S4433 Measurement Circuitry" on page 10 and "ATtiny15 Measurement Circuitry" on page 12.

For NiCd battery, charge is started if the battery temperature is within the temperature range. Charge is always terminated with an error message if the temperature is higher than the maximum temperature, if the voltage exceeds the maximum battery voltage or if the maximum fast-charge time expires.

The normal ways to detect that the battery is fully charged, are the Temperature Rise (dT/dt) and the Voltage Drop (-dV/dt) methods. Therefore, a sample is taken every minute for the temperature and every second of the voltage. The values are compared to the sample taken one minute/second ago. In case the battery is fully charged, the charge status is automatically changed to trickle-charge, causing the program to jump into the trickle\_charge() function.

The trickle\_charge() function executes in a loop checking for a change of the charge status, temperature and voltage measurement and adjusting the current. In case the temperature is outside the valid range or a voltage overflow is detected, the error flag is set and the function is terminated. If no error occurs and charge status is not changed by the user, the program loops forever, adjusting the charge current to the current defined at the top of this module.

## 4.1 User Settings

The charger is built as a multipurpose charger that can charge four types of batteries and a various number of cells by changing parameters before compiling the code. It is very important that this is done properly before compiling or it can damage the battery and the surroundings.

### 4.1.1 Change Battery Type

There is a C-file and an h-file for each battery type. Include the desired battery files in the compiler before compiling and "uncomment" the battery type under "Battery Type" in B\_Def.h

### 4.1.2 Change Number of Cells

Change parameter "cells" in B\_Def.h

### 4.1.3 Change Cell Capacity

Change parameter "capacity" in B\_Def.h

### 4.1.4 Change Li-Ion Cell Voltage

Change parameter "cell\_voltage" in B\_Def.h

### 4.1.5 Change ADC Step Size

After changing the resistor values as described in the Measurement section, the parameters "voltage\_step" and "current\_step" must be changed in B\_Def.h. This is very important and may damage the charger if not done properly.



## 4.2 Source Code Files

The following files are included in the source code directory:

**Table 4-1. C Source Code Files**

File Name	Description	Code Size <sup>(1)</sup>
Io4333.h	Header file with symbolic names for AT90S4333	
cstartup.s90	Start-up files for the C-compiler	
Lnk0t.xcl	Command file for the linker, optimized for AT90S4433	
B_def.h	Defines battery type, cell voltage, battery capacity and voltage steps	
Bc.h	Header file for bc.c, constants and macro definitions	
Bc.c	Main program, common for all battery types	474 bytes
SLA.h	Header file for Lead Acid battery, charger parameters and function declarations	
SLA.c	Source code for Lead Acid battery	446 bytes
NiCd.h	Header file for Nickel Cadmium battery, charger parameters and function declarations	
NiCd.c	Source code for Nickel Cadmium battery	548 bytes
NiMh.h	Header file for Nickel Metal Hydride battery, charger parameters and function declarations	
NiMh.c	Source code for Nickel Metal Hydride battery	514 bytes
Liion.h	Header file for Lithium-Ion battery, charger parameters and function declarations	
Liion.c	Source code for Lithium-Ion battery	690 bytes

Notes: 1. The Code Size applies for version 1.0 of the code. Compiled with IAR compiler version 1.41C, maximum size optimization

**Table 4-2. Assembly Source Code Files**

File Name	Description	Code Size
bc.inc	Include file for register definitions, A/D channel definitions and general constants	
tn15def.inc	Include file for ATtiny15	
NiCd.inc	Include file for Nickel Cadmium battery, charger parameters	
NiCd.asm	Source code for Nickel Cadmium battery	324 bytes
NiMh.inc	Include file for Nickel Metal Hydride battery, charger parameters	
NiCd.asm	Source code for Nickel Metal Hydride battery	328 bytes
Liion.inc	Include file for Lithium-Ion battery, charger parameters	
Liion.asm	Source code for Lithium-Ion battery	340 bytes

### 4.3 BC.C

This module contains the main function, the setup and the UART functions, the real-time clock and the interrupt handling routines.

In the “setup” routine, all low-level initialization are done. The UART is initialized and the real-time clock set to zero. After the initialization the program loops in idle mode until the status is changed in the global status variable.

The real-time clock is started when the PWM is started, and is also stopped when the PWM is stopped, i.e., when the battery voltage is measured. This ensures that only the time when the battery is charged is taken into account. On the other hand, this method has the disadvantage that measurements that rely on time ( $dV/dt$  or  $dT/dt$ ) may be inaccurate.

The user can cause an external interrupt by pressing a button to change the charge status. In the interrupt handling routine, the status is changed according to the button pressed, either to “fast-charge” or to “trickle-charge”. In the main function the program then calls a function depending on the value set in the “charge status” variable.

BC.C also includes some common functions used by the different battery programs. The two most important functions will be described in the following subsections.

Figure 4-1. The Main() Function

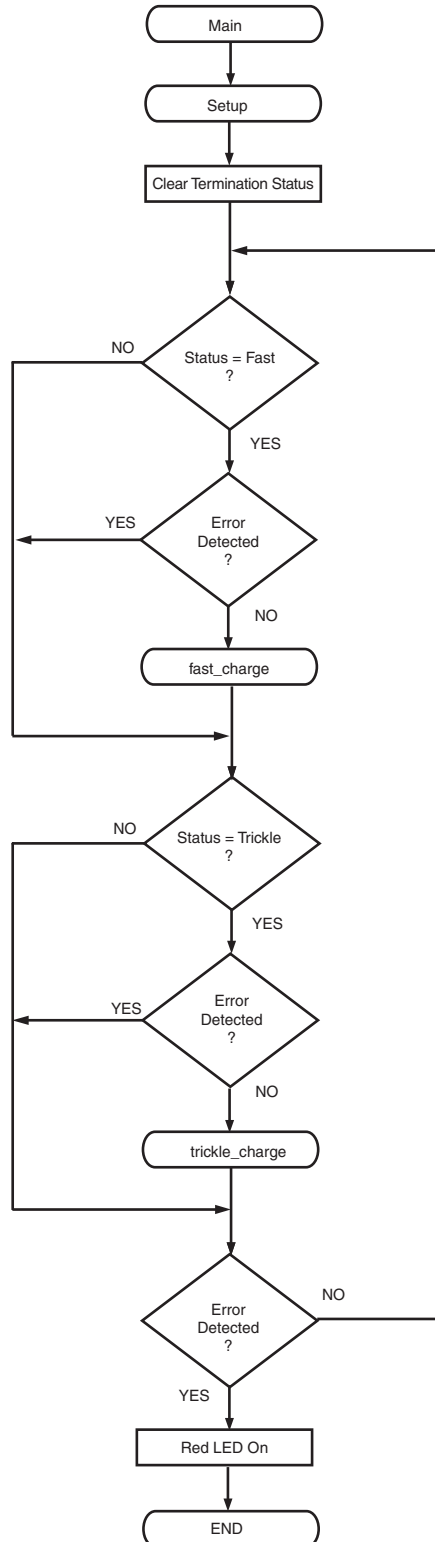

4.3.1 int battery (Unsigned Char Value)

The function is called for each A/D conversion and controls the ADC registers and PWM according to the measurement requested. It reads eight measurements from the ADC and calculates an average, which is returned to the calling function.

Figure 4-2. The Battery() Function

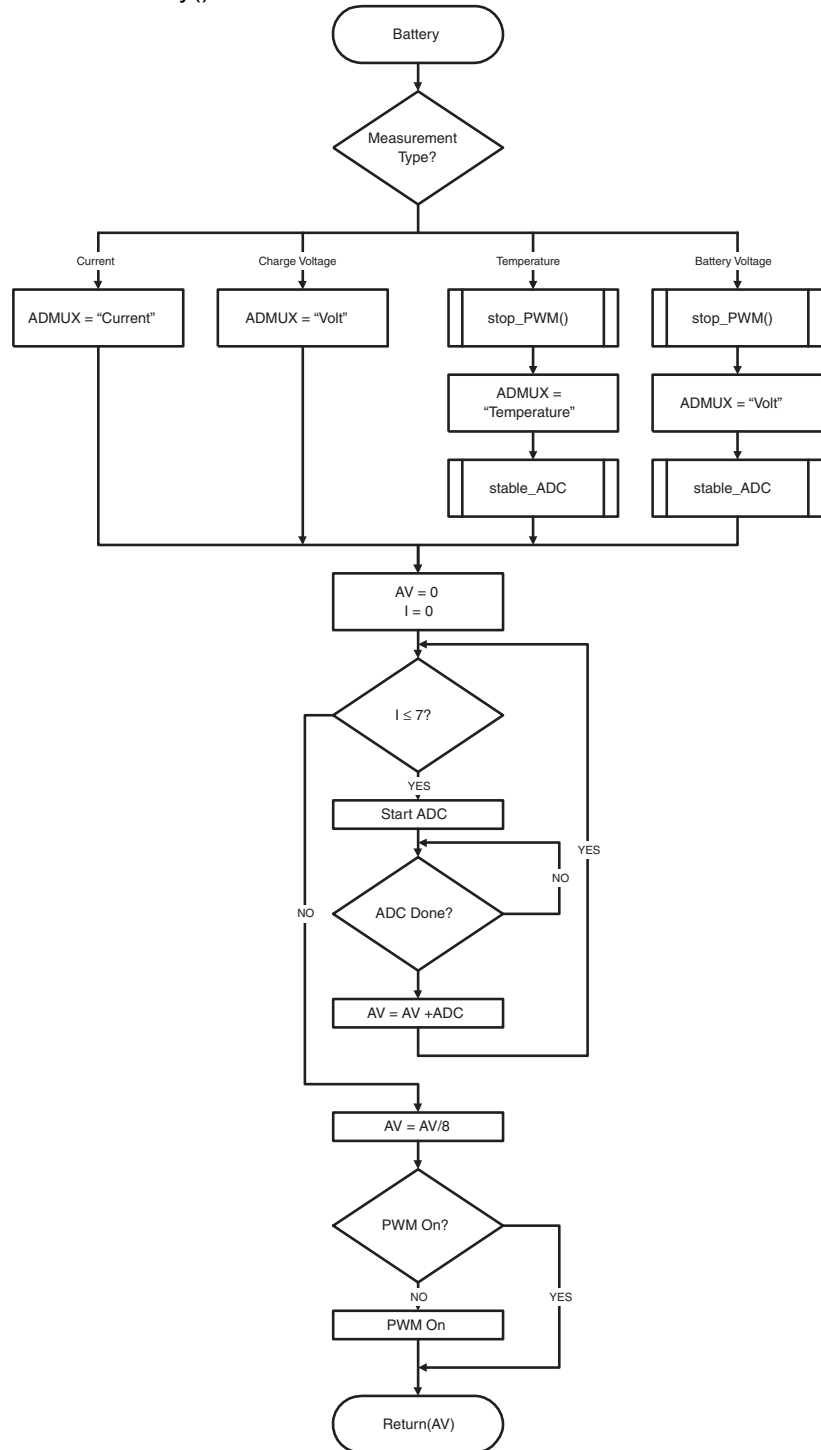

### 4.3.2 void stable\_ADC (Void)

The stable\_ADC function is used when measuring battery voltage or temperature. It makes sure the ADC values are stable inside a defined area. This is important for an accurate measurement. The function loops until it gets three ADC values where the highest is no more than one step higher than the lowest.

**Figure 4-3.** The stable\_ADC() Function

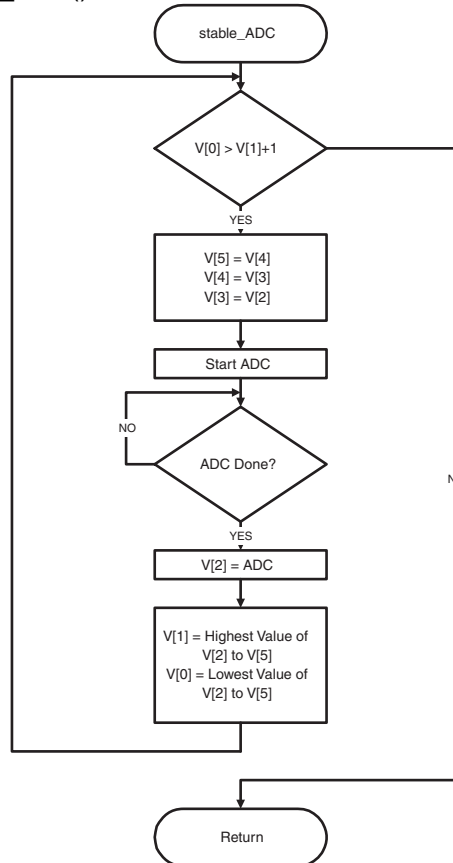

### 4.4 BC.H

In this module, the bit handling macros, the charge status and the termination bit mask constants are defined.

The “charge status” indicates the actual status of the battery charger; fast-charging, trickle charging or if an error has occurred. For Li-Ion and SLA battery types, an indication on the charge mode, constant voltage or constant current is included as well as if Li-Ion is in the final stage of its fast-charge mode (called “delay”). The “termination” indicates the reason why fast-charge mode terminated or in case of a charge error where the error was detected and can be used for program debugging.

### 4.5 B\_DEF.H

This module defines the battery to be charged. When a customer designs a battery charger using the given circuit and program code, this file has to be changed to meet the needs.

The battery type defines the charging and termination algorithm. If more than one battery type is chosen an error will occur during linking the program, as all functions with the same functions for different battery types have the same names `battery()`, `fast_charge()` and `trickle_charge()`. An error message will also occur if no battery type is chosen.

The cell number determines the voltage of the battery pack and all related constants. It is assumed that all cells are in series. Zero cells are not very reasonable but will only result in zero charge current. The voltage range of the buck converter and the voltage measurement circuit sets the upper limit.

The capacity (in mA) defines the charge current and all related constants.

All battery types except SLA, are fast charged in a “conservative” way at 1C. SLA is charged with 2C. This sets the limit for the battery capacity. The buck converter is calculated to supply a maximum current of 1.5 A. The maximum capacity for SLA is 750 mAh, for the other battery types 1500 mAh. If a higher charge current for NiCd or NiMH is required, the buck converter layout has to be changed. In case of a current higher than 2 A, the current measurement circuit also need some modifications. If batteries with a higher capacity than calculated above should be charged, it is possible to change the buck converter or to reduce charge current.

For the Li-Ion battery type, two cell voltages exist, depending on the battery manufacturer. This voltage, 4.1V or 4.2V, must be edited. It will be included automatically if the Li-Ion definition is chosen. Stating a wrong voltage in this place will not necessarily result in an error message, but will lead to incorrect charge methods, which can damage the battery and the battery charger.

The ADC step parameters are to be edited according to the resistors used in the measurement circuitry. This is described under measurement circuits.

The NTC table defines the ADC step value. A step value indicates 0.5°C change in the temperature. This lookup table is used in NiCd charging. The table may be edited if the NTC is different from the used in this description.

## 4.6 SLA.C

### 4.6.1 Charge Method

Fast-charge of Sealed Lead Acid batteries uses constant voltage. Before charging begins, a simple (but surprisingly effective) method is used to determine the charge voltage. A constant current of 1C (10 mA) is applied and the corresponding battery voltage is measured.

The battery is first charged with Constant voltage, fixing the voltage to that level and let the current float. When the current drops below 0.2C the charge cycle has finished. Fast-charge mode is then terminated and trickle-charge mode started.

Trickle charge is a constant voltage charging at a level slightly below the fast-charge voltage. Trickle charge can be terminated after a set time.

### 4.6.2 Charge Parameter Summary

Fast-charge:

Fixed fast-charge voltage = cells \* 2450 mV

Trickle charge:

Fixed trickle-charge voltage = cells \* 2250 mV

General charge termination:

Absolute minimum temperature  $T = 0^{\circ}\text{C}$

Absolute maximum temperature  $T = 45^{\circ}\text{C}$

Fast-charge termination:

Minimum current threshold  $I = 0.2\text{C}$

Fast-charge error:

Maximum fast-charge temperature  $T = 30^{\circ}\text{C}$

Maximum fast-charge time  $t = 60$  min at 1C current

Maximum fast-charge current  $I = 2\text{C}$

Trickle charge termination:

None

**Figure 4-4.** The Trickle\_charge() Function for SLA

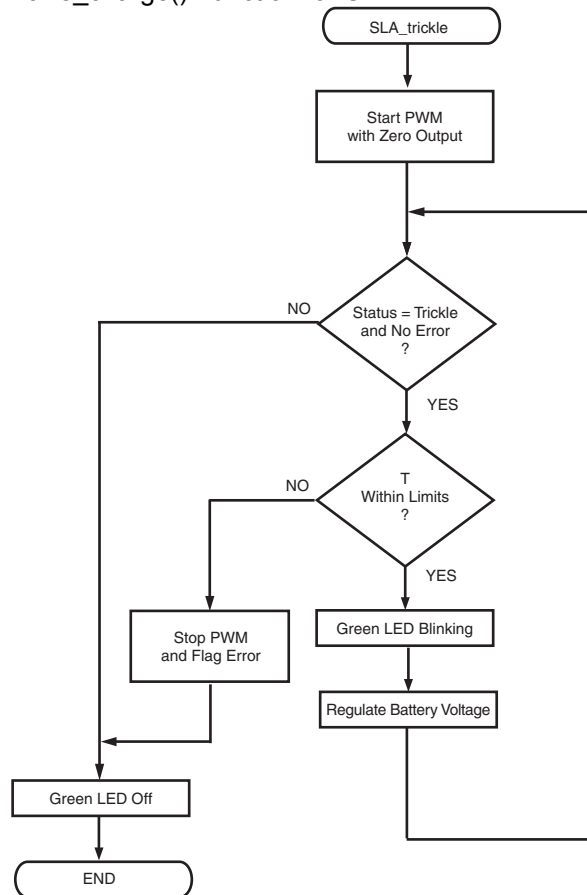
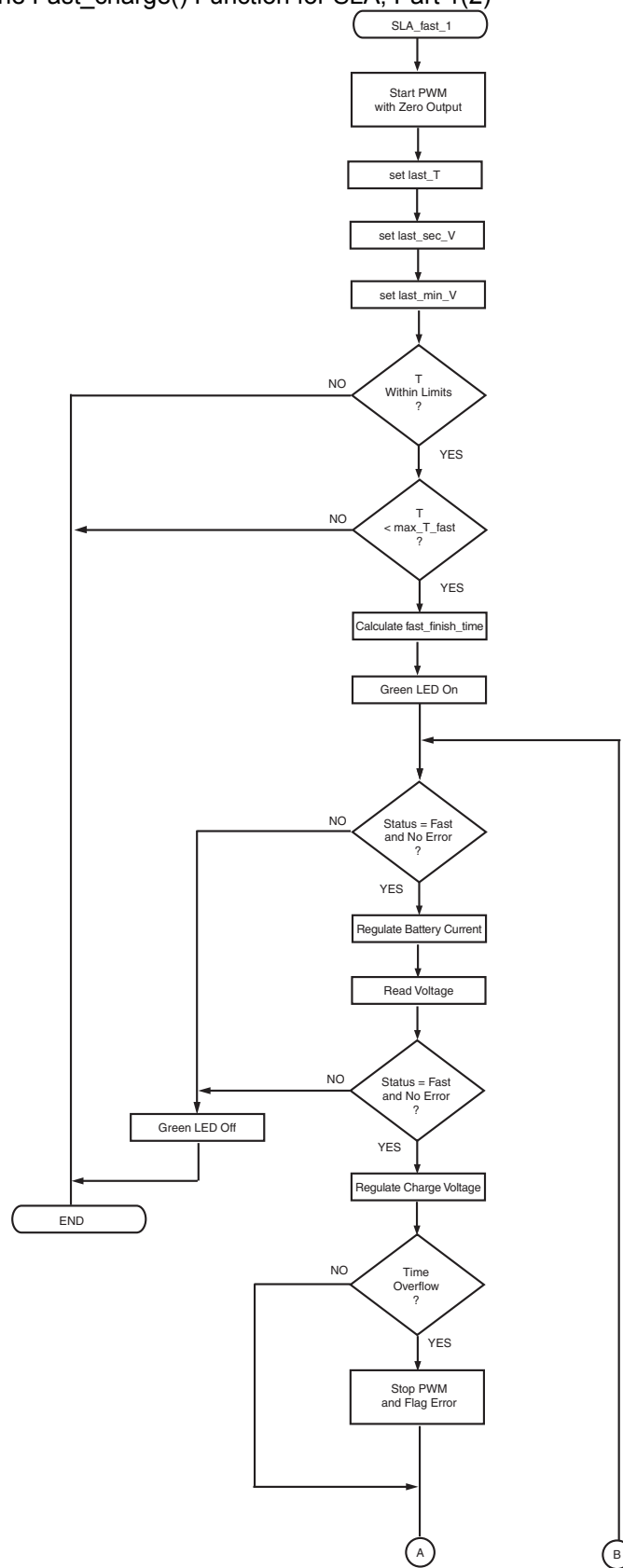
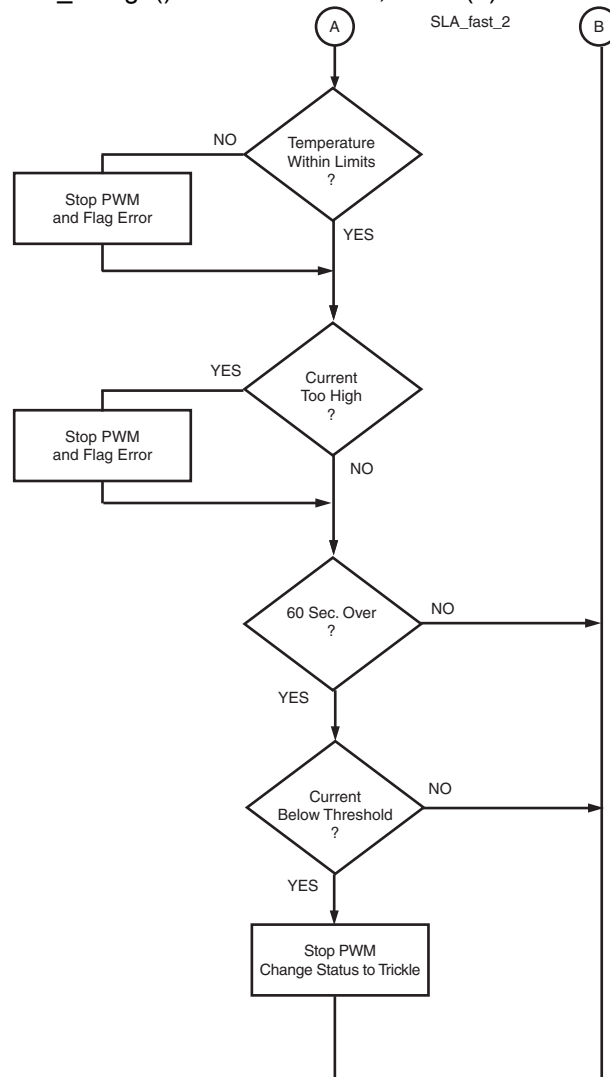

Figure 4-5. The Fast\_charge() Function for SLA, Part 1(2)



**Figure 4-6.** The Fast\_charge() Function for SLA, Part 2(2)



## 4.7 NiCd.C

### 4.7.1 Charge Method

NiCd battery types are charged with a constant current. In fast-charge mode this current is set to 1C. In trickle-charge mode, it is C/40. The charging is terminated by the Voltage Drop (-dV/dt) method. Maximum charge voltage, Temperature Rise (dT/dt), and maximum charge time are used as backup terminations.

In case the battery is fully charged, the charge status is automatically changed to trickle-charge, causing the program to jump into the trickle\_charge() function.

### 4.7.2 Charge Parameter Summary

Charge conditions:

Fast-charge:

Fast-charge current = 1C

Trickle charge:

Trickle charge current = 0.025C

General charge termination:

Absolute minimum temperature  $T = 5^{\circ}\text{C}$

Absolute maximum temperature  $T = 40^{\circ}\text{C}$

Absolute maximum charge voltage  $V = \text{cells} * 1500 \text{ mV}$

Fast-charge termination:

Voltage drop threshold  $-dV/dt = 20 \text{ mV/min per cell}$

Temperature rise threshold  $dT/dt = 1^{\circ}\text{C per minute}$

Fast-charge error:

Minimum fast-charge temperature  $T = 15^{\circ}\text{C}$

Maximum fast-charge time  $t = 90 \text{ min at 1C current}$

**Figure 4-7.** The Trickle\_charge() Function for NiCd

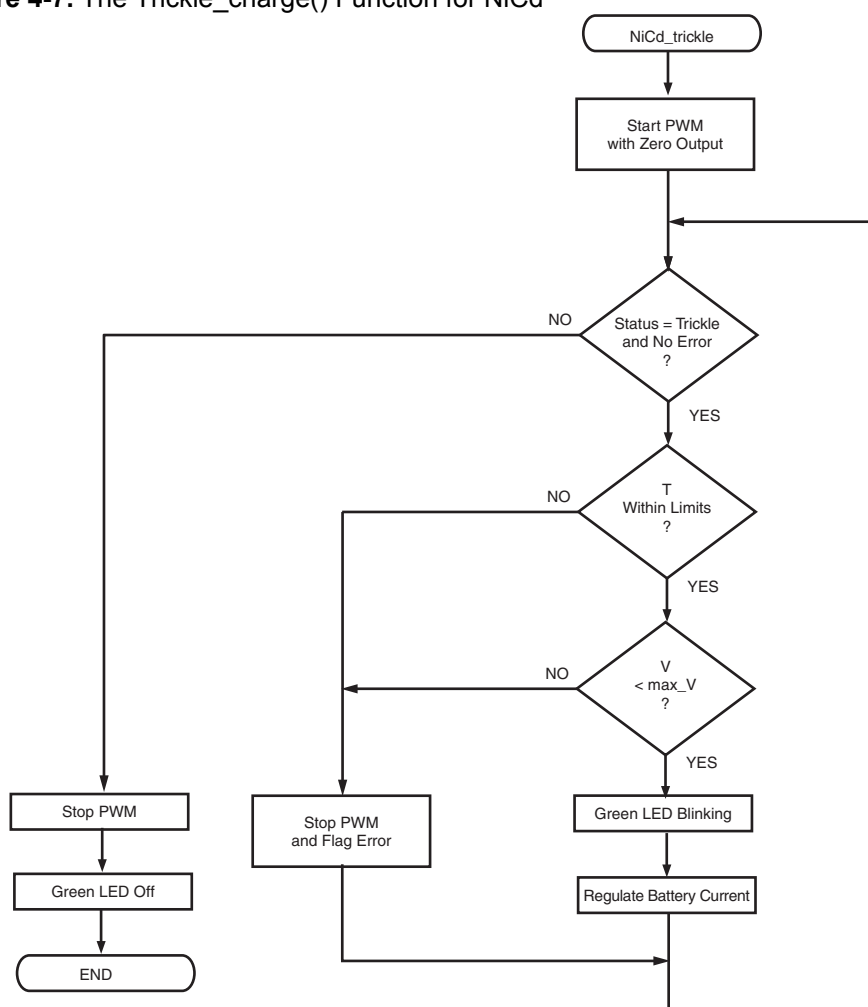

Figure 4-8. The Fast\_charge() Function for NiCd, Part 1(2)

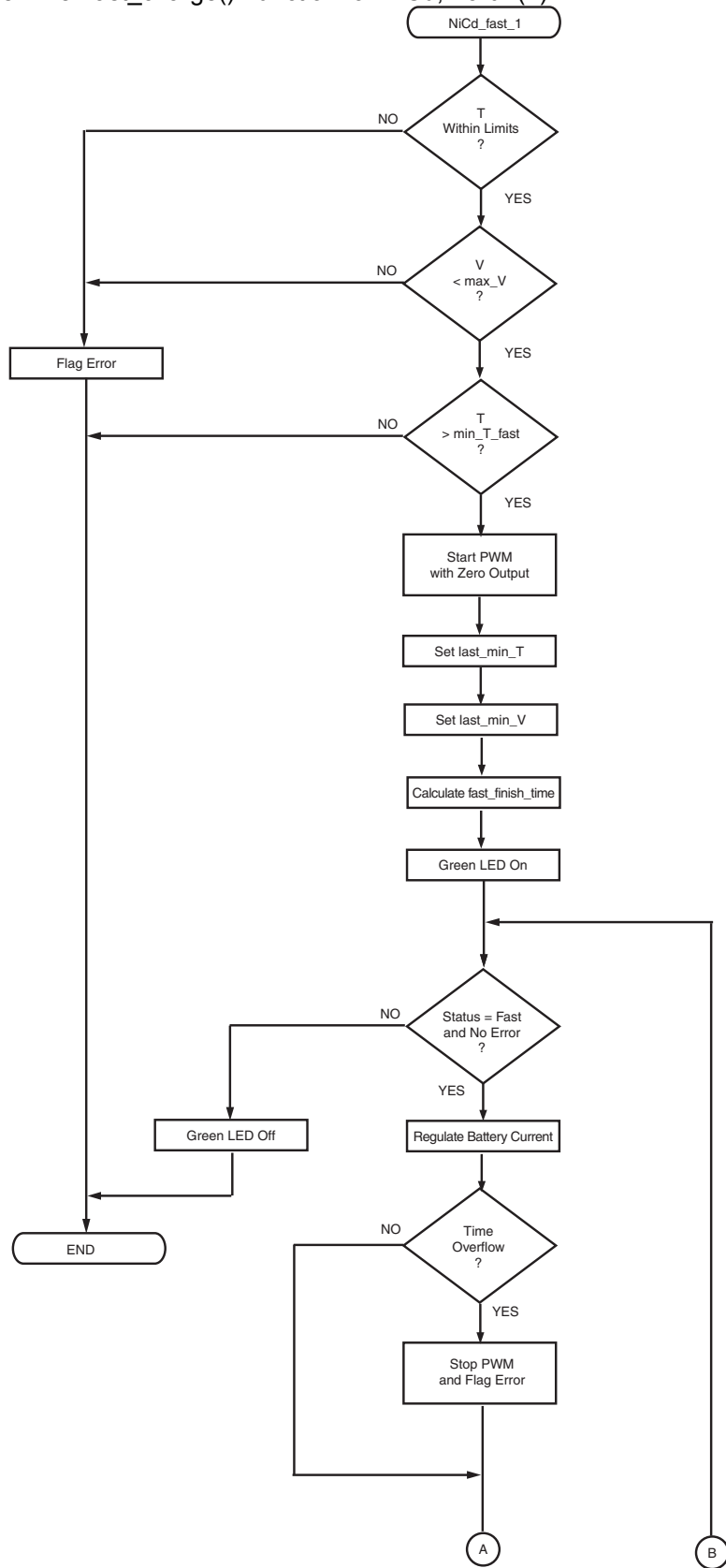
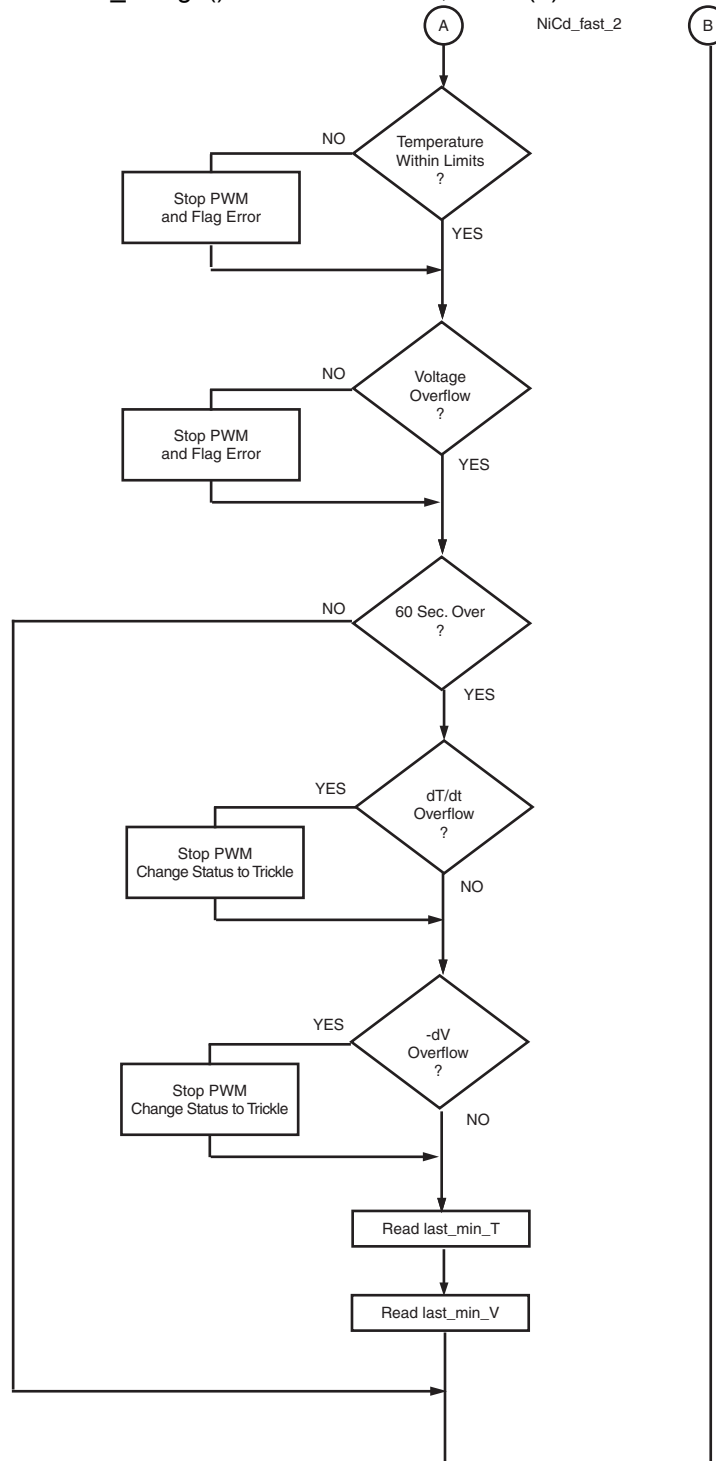

Figure 4-9. The Fast\_charge() Function for NiCd, Part 2(2)





## 4.8 NiMH.C

### 4.8.1 Charge Method

NiMH battery types are charged with a constant current. In fast-charge mode, this current is set to 1C. In trickle-charge mode it is C/40.

The charging is terminated by the Temperature Rise (dT/dt) and the Voltage Drop (-dV/dt) methods. Maximum charge voltage and maximum charge time are used as backup terminations.

In case the battery is fully charged the charge status is automatically changed to trickle-charge, causing the program to jump into the trickle\_charge() function.

### 4.8.2 Charge Parameter Summary

Charge conditions:

Fast-charge:

Fast-charge current:  $I = 1C$

Trickle charge:

Trickle charge current:  $I = 0.025C$

Maximum trickle-charge time  $t = 90$  min at 0.025C current

General charge termination:

Absolute minimum temperature =  $5^{\circ}C$

Absolute maximum temperature =  $40^{\circ}C$

Absolute maximum charge voltage = cells \* 1500 mV

Fast-charge termination:

Temperature rise threshold  $dT/dt = 0.5^{\circ}C$  per minute

Fast-charge error:

Minimum fast-charge temperature  $T = 15^{\circ}C$

Maximum fast-charge time  $t = 90$  min at 1C current

Figure 4-10. The Trickle\_charge() Function for NiMH

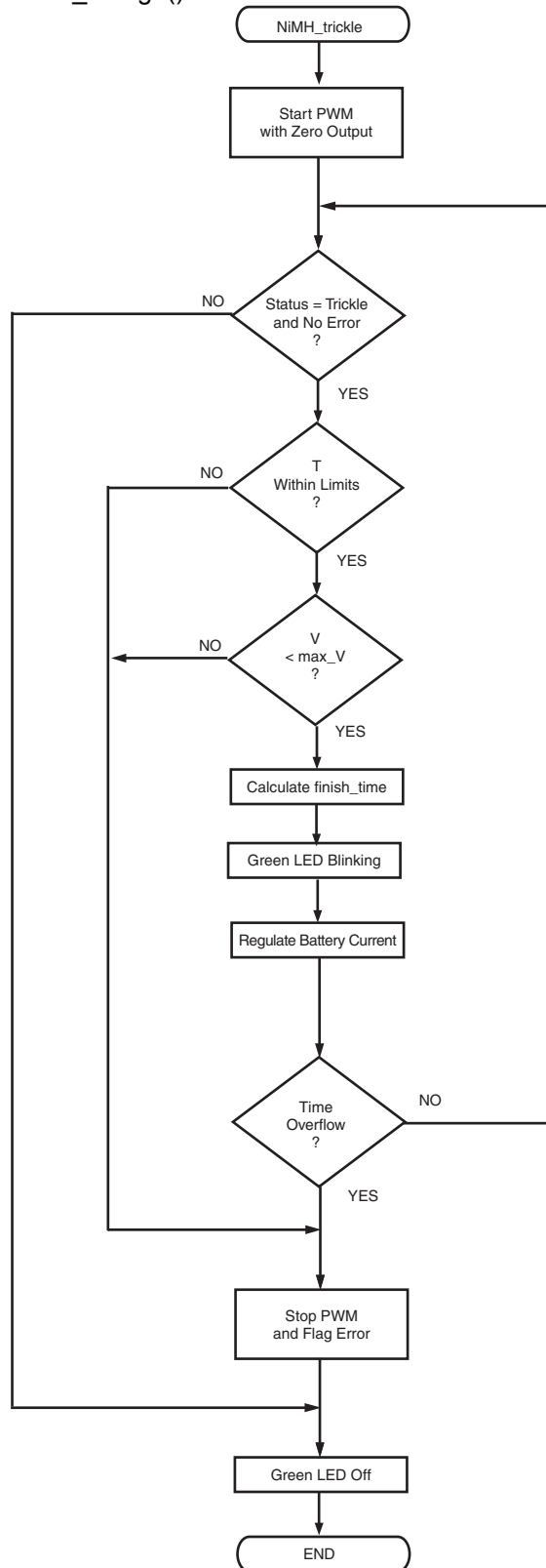

Figure 4-11. The Fast\_charge() Function for NiMH, Part 1(2)

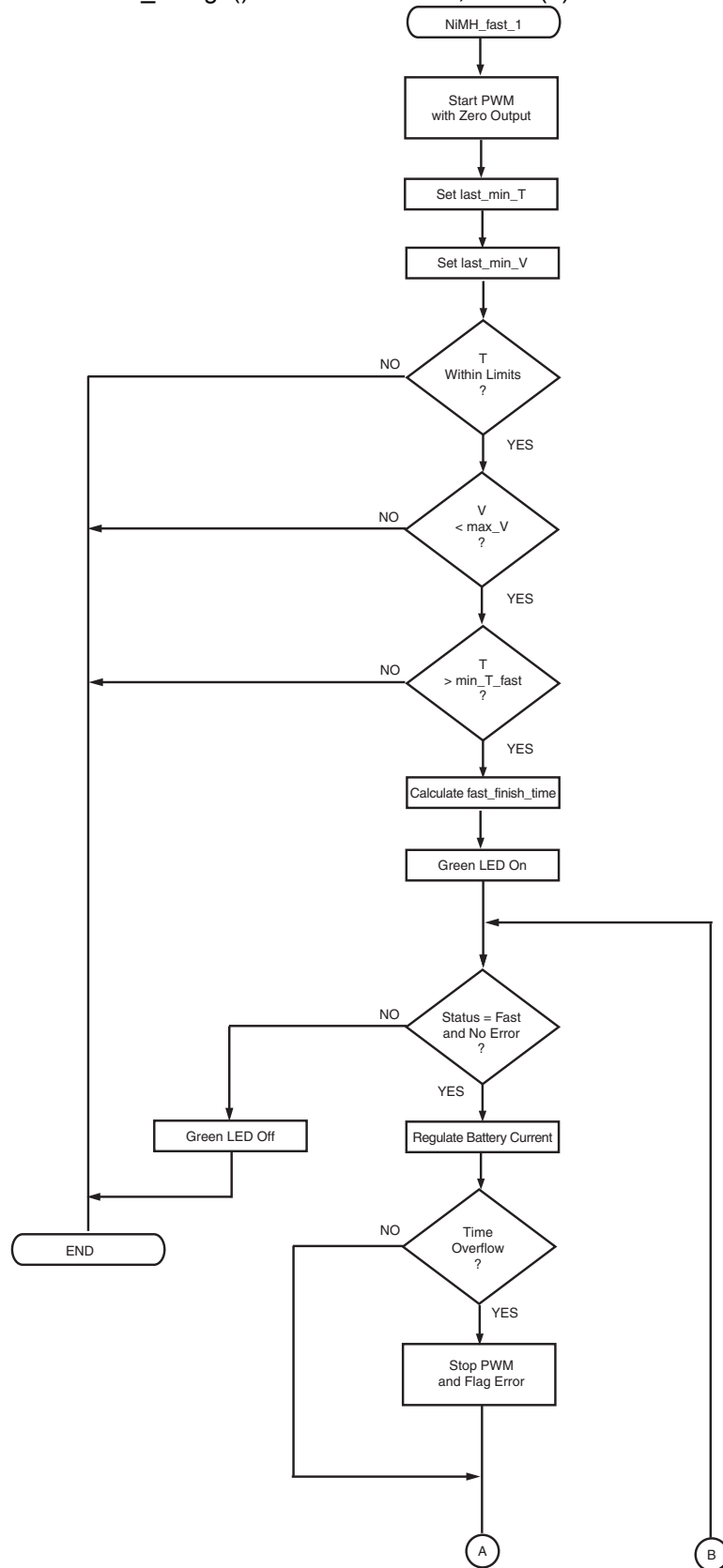
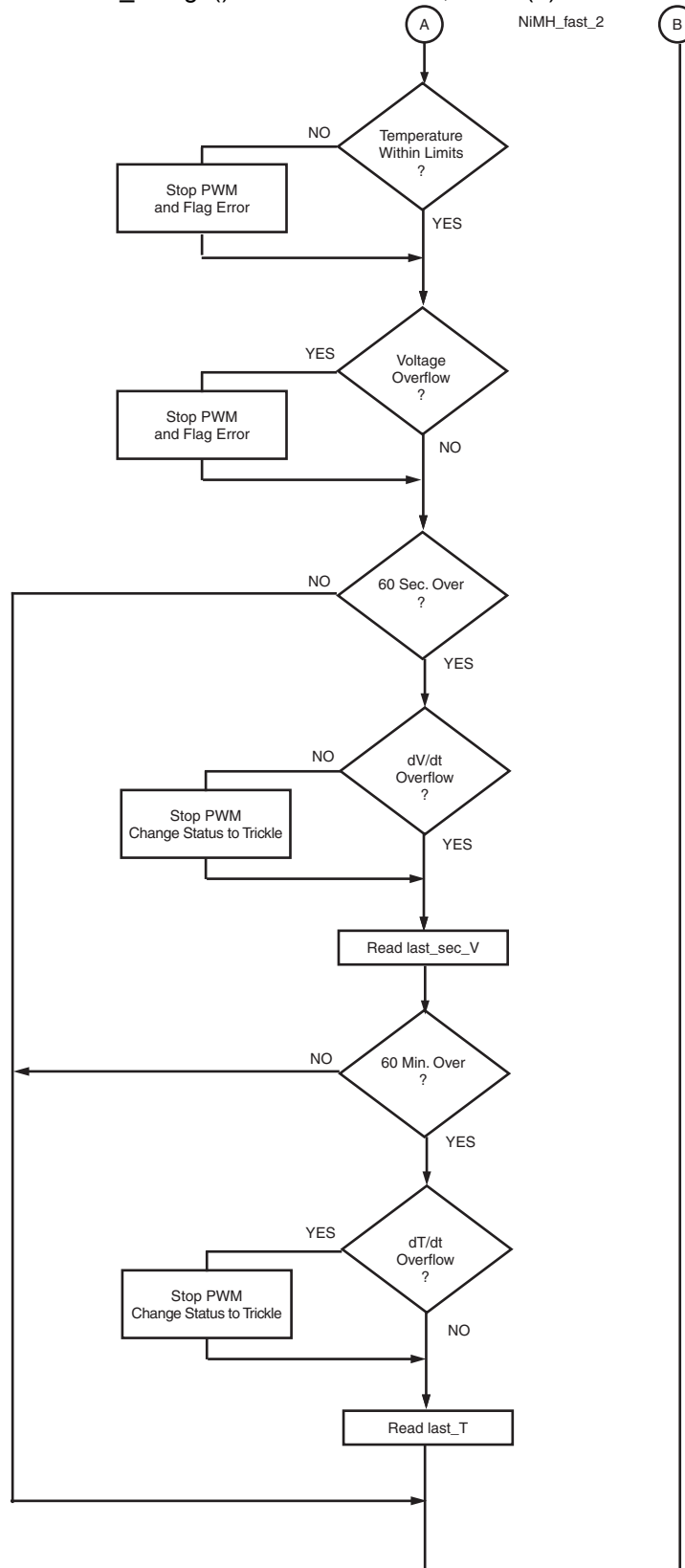

Figure 4-12. The Fast\_charge() Function for NiMH, Part 2(2)



## 4.9 Lilon.C

### 4.9.1 Charge Method

Li-Ion batteries are the most advanced battery types to charge. Fast-charge starts at a constant current of 1C. This current is kept constant until a cell voltage level of 4.1 or  $4.2V \pm 50 \text{ mV}$  is set. Then the battery is charged with constant voltage until the current drops below  $I_{\text{min}}$ .

For an accurate measurement of the battery voltage (and not the charge voltage), the PWM is turned off during voltage measurements. If the charge method then changes from “constant current” to “constant voltage”, the charge voltage is the relevant parameter to be measured. This is the reason why there are two voltage measurement modes, one with “PWM turn off” and one without.

Trickle charge of Li-Ion batteries is in principle the same as fast-charge. The current is much lower than in fast-charge mode and the constant voltage phase of the trickle-charge mode is simply terminated by a timer.

### 4.9.2 Charge Parameter Summary

Charge conditions:

Fast-charge:

Absolute maximum charge voltage = cells \* cell voltage

Voltage tolerance = cells \* 50 mV

Fast-charge current = 1C

Minimum current threshold = 50 mA per cell

Trickle charge:

Trickle charge current = 0.025C

Maximum trickle-charge time = 90 min at 0.025C current

General charge termination:

Absolute minimum temperature  $T = 5^{\circ}\text{C}$

Absolute maximum temperature  $T = 40^{\circ}\text{C}$

Fast-charge termination:

See “charge conditions”

Fast-charge error:

Minimum fast-charge temperature  $10^{\circ}\text{C}$

Maximum fast-charge time = 90 min at 1C current

Figure 4-13. The Trickle\_charge() Function for Li-Ion

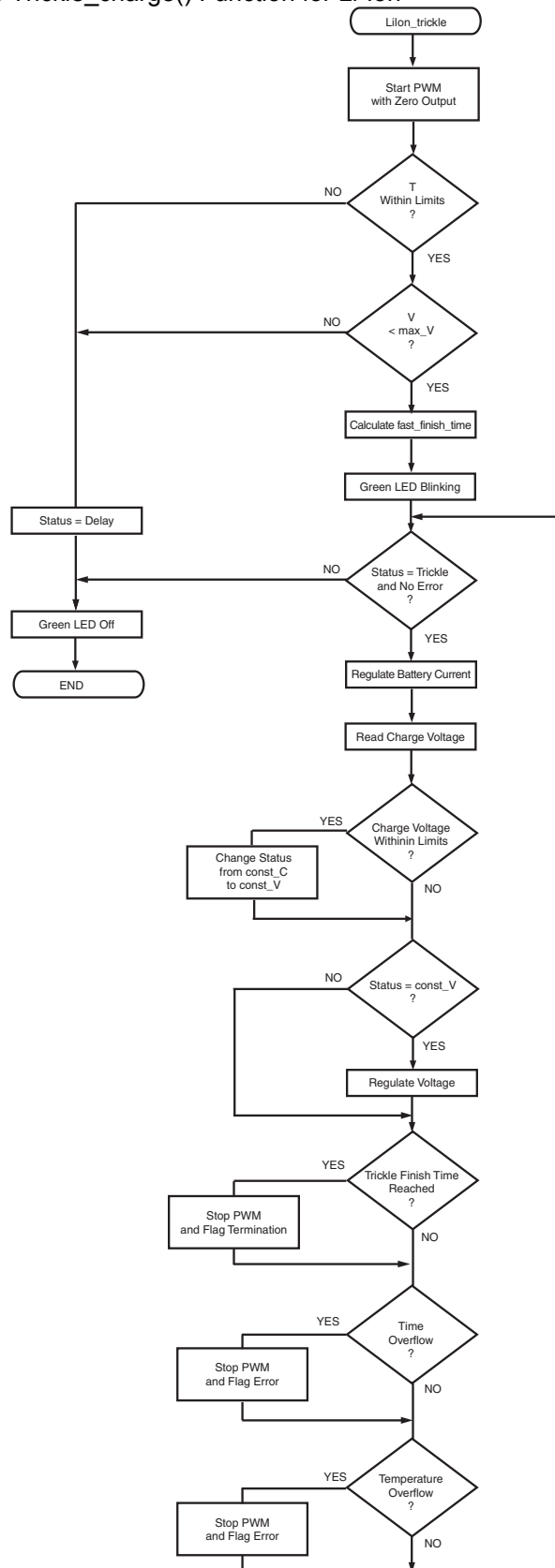

Figure 4-14. The Fast\_charge() Function for Li-Ion, Part 1(2)

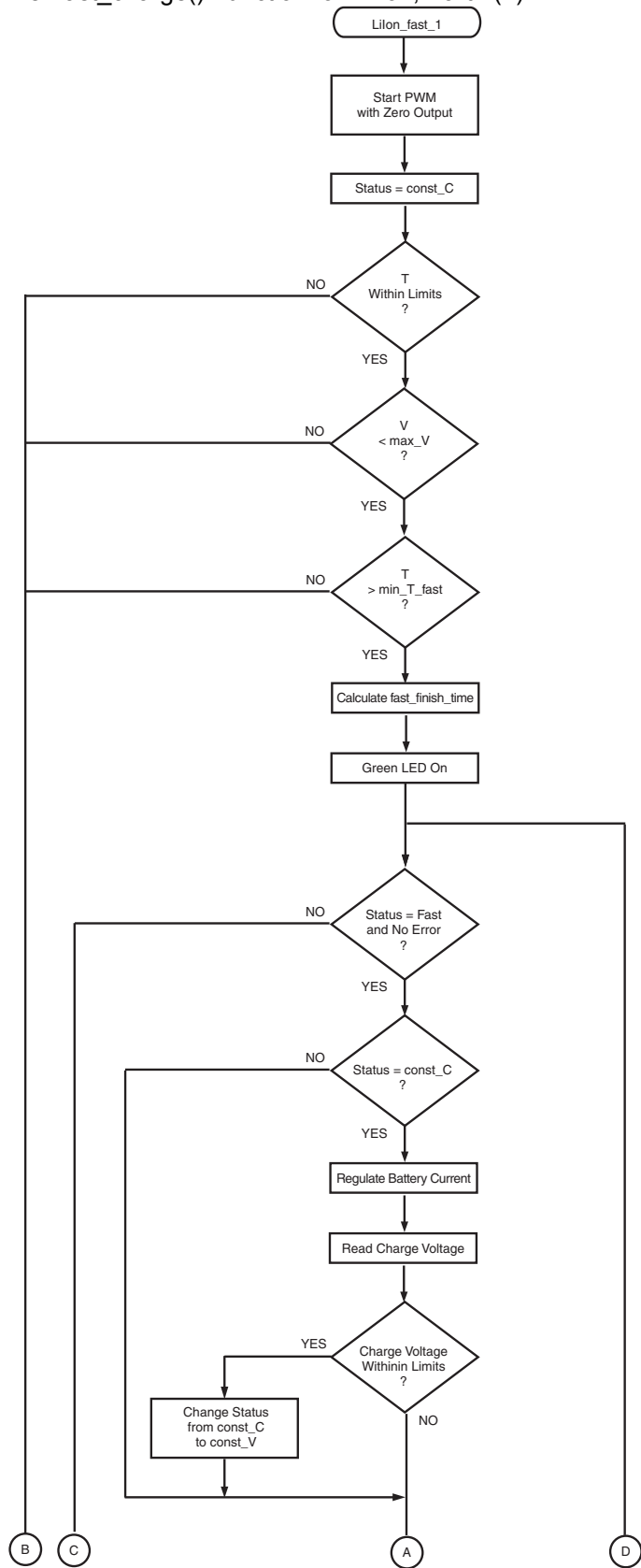
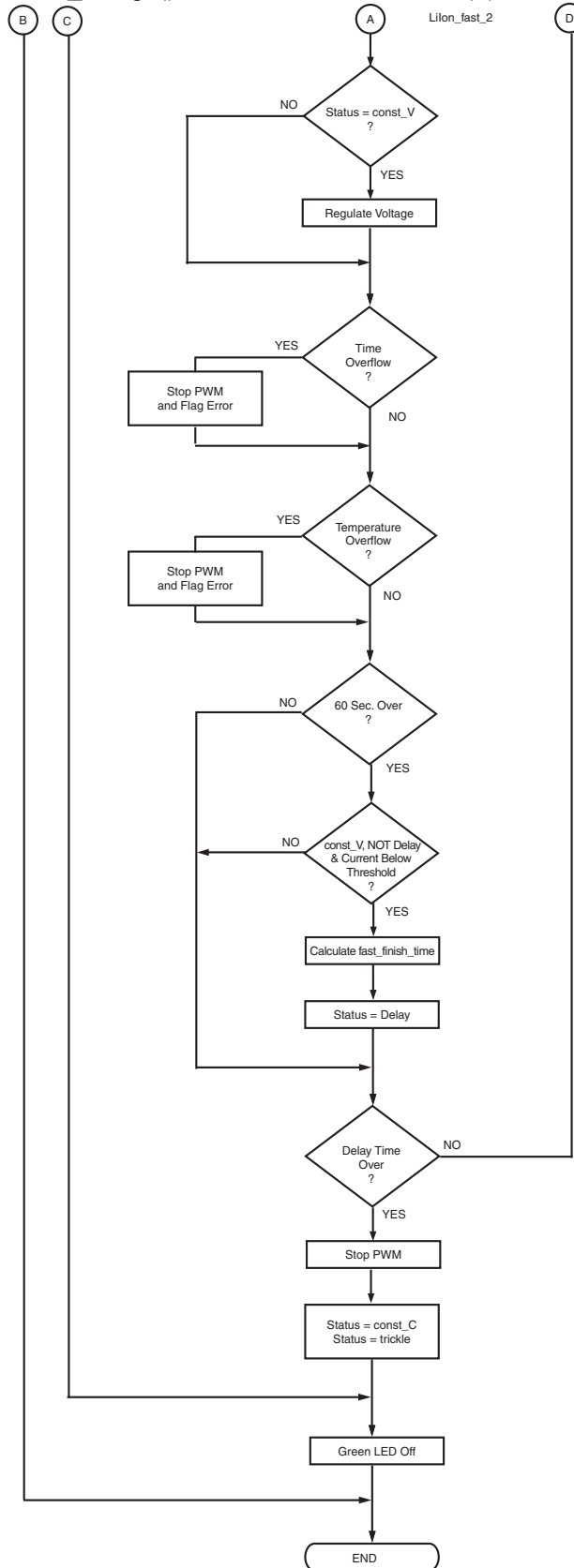

Figure 4-15. The Fast\_charge() Function for Li-Ion, Part 2(2)





## 5 Suggested Improvements

NiCd batteries suffer from “Memory Effect” – after charging the battery several times, it will not charge completely. To reset the “memory”, a shunt resistor can be added, allowing the MCU to completely discharge the battery prior to charging.

# Appendix 1: Schematic

Figure 5-1. Block Diagram of Main Blocks

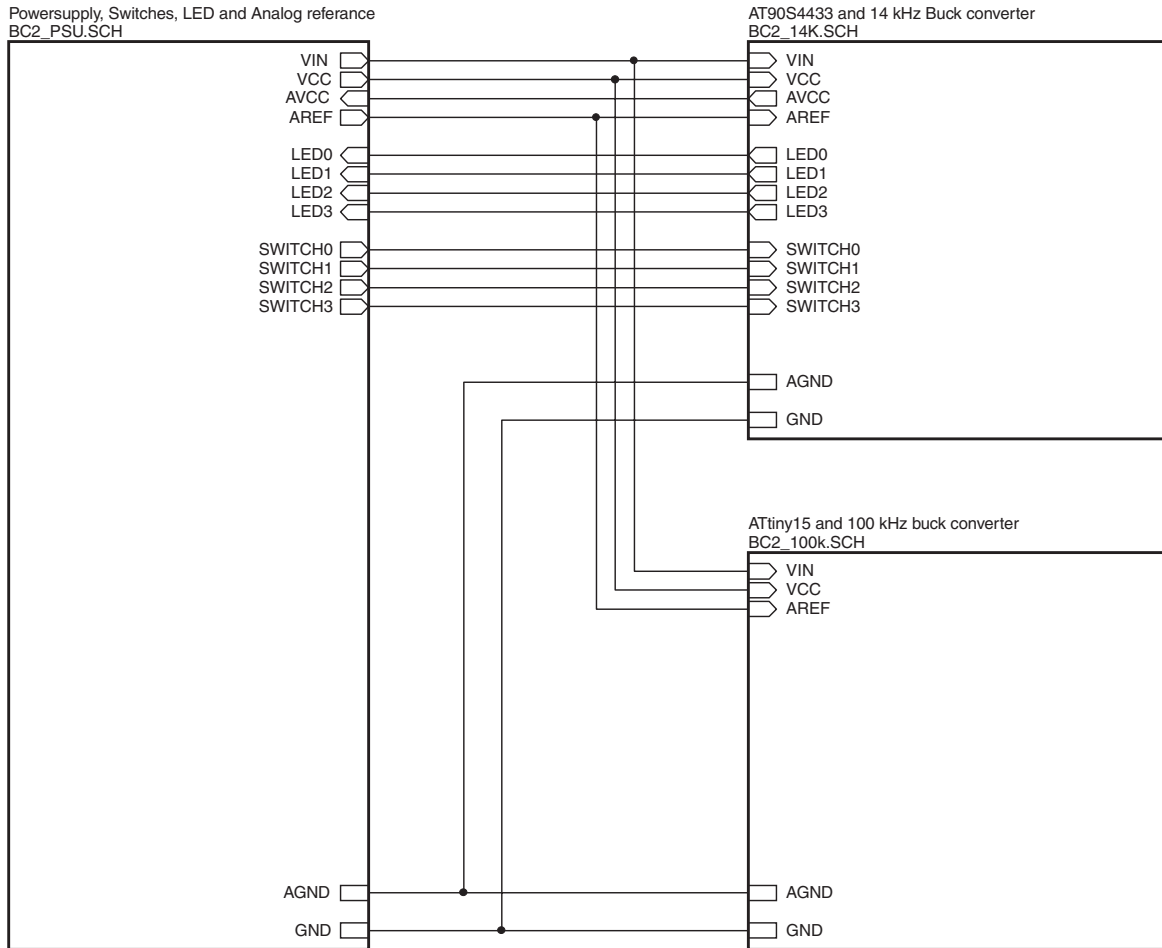
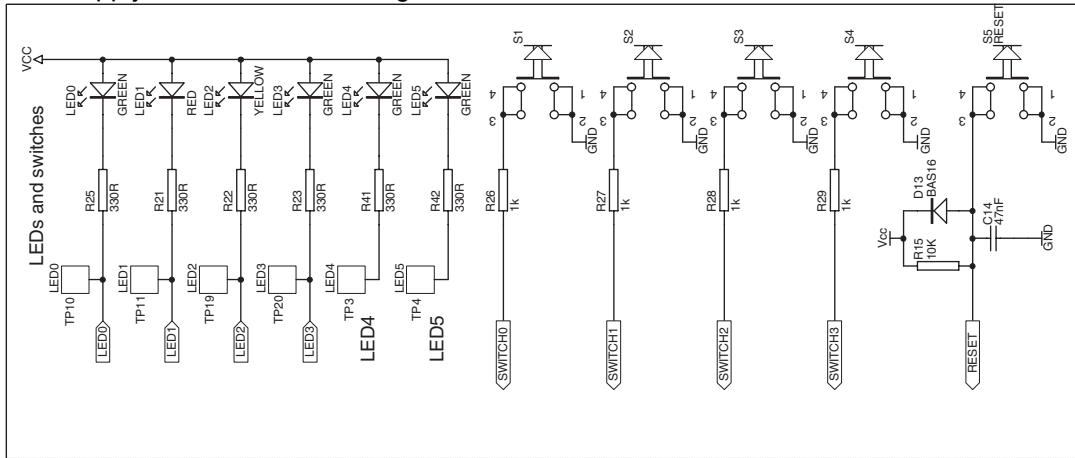

Figure 5-2. Power Supply and Reference Voltage Schematic



Testpoint TP3, TP4, TP10, TP11, TP19 and TP20 have no marking in the silkscreen. They are placed close to their respective resistors making it easy to (if desired) cut the track and patch the LED to an other function.

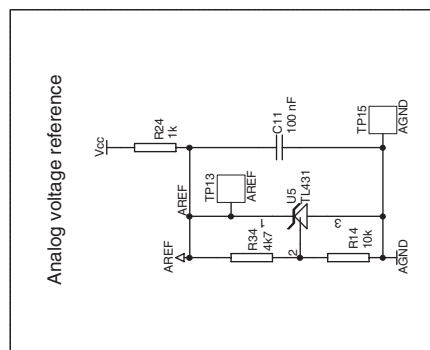
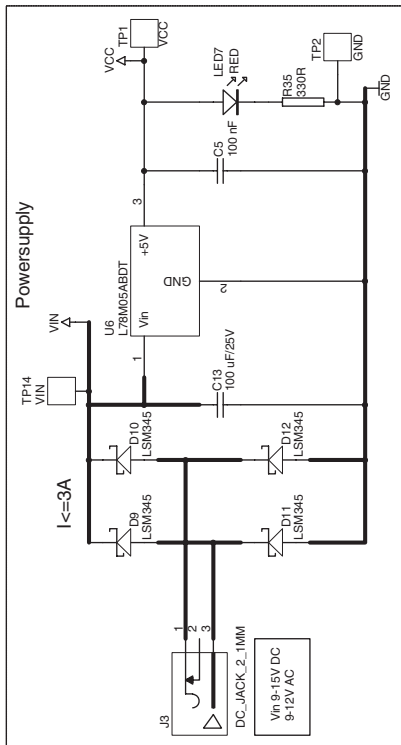

Figure 5-3. ATtiny15 and 100 kHz Buck Converter Schematic

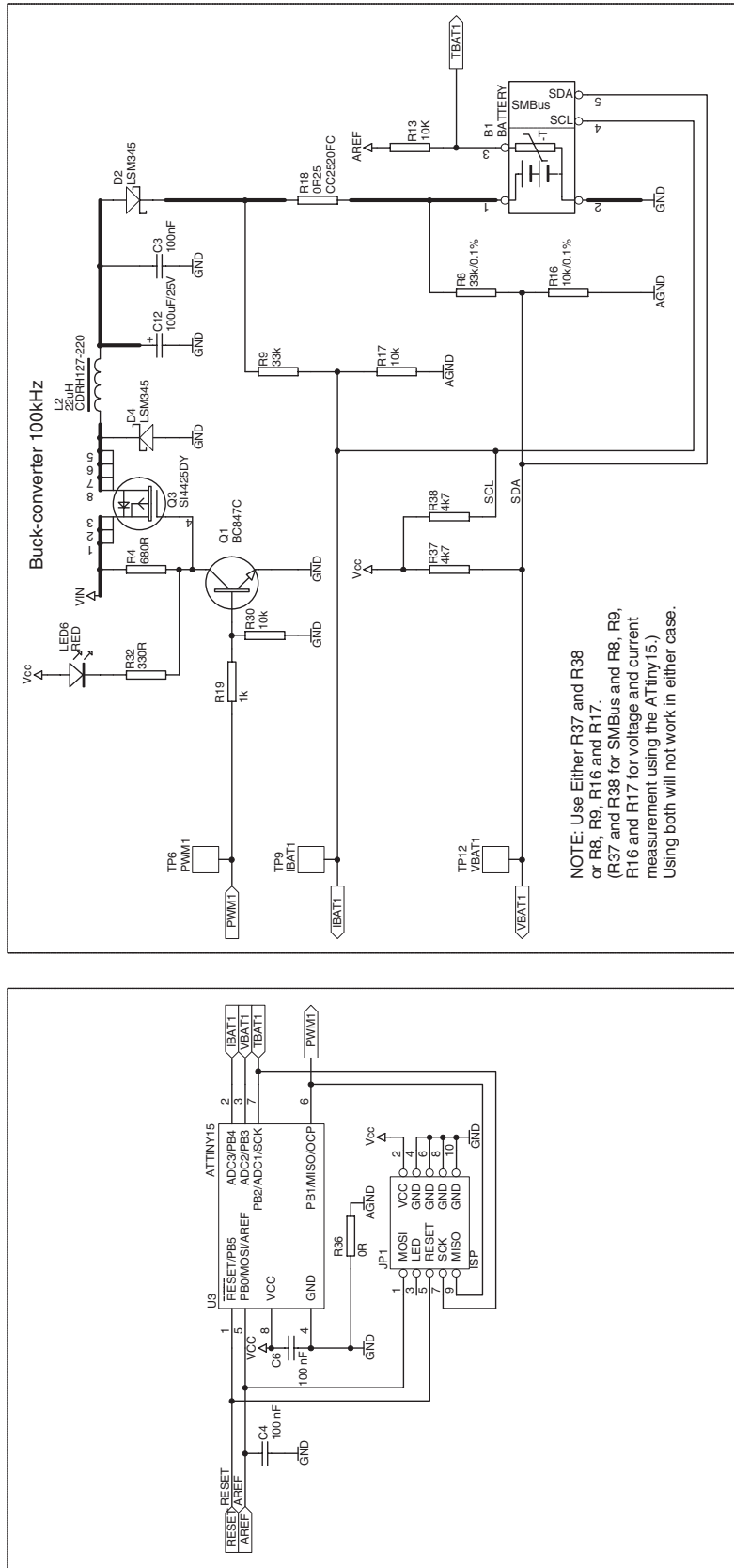
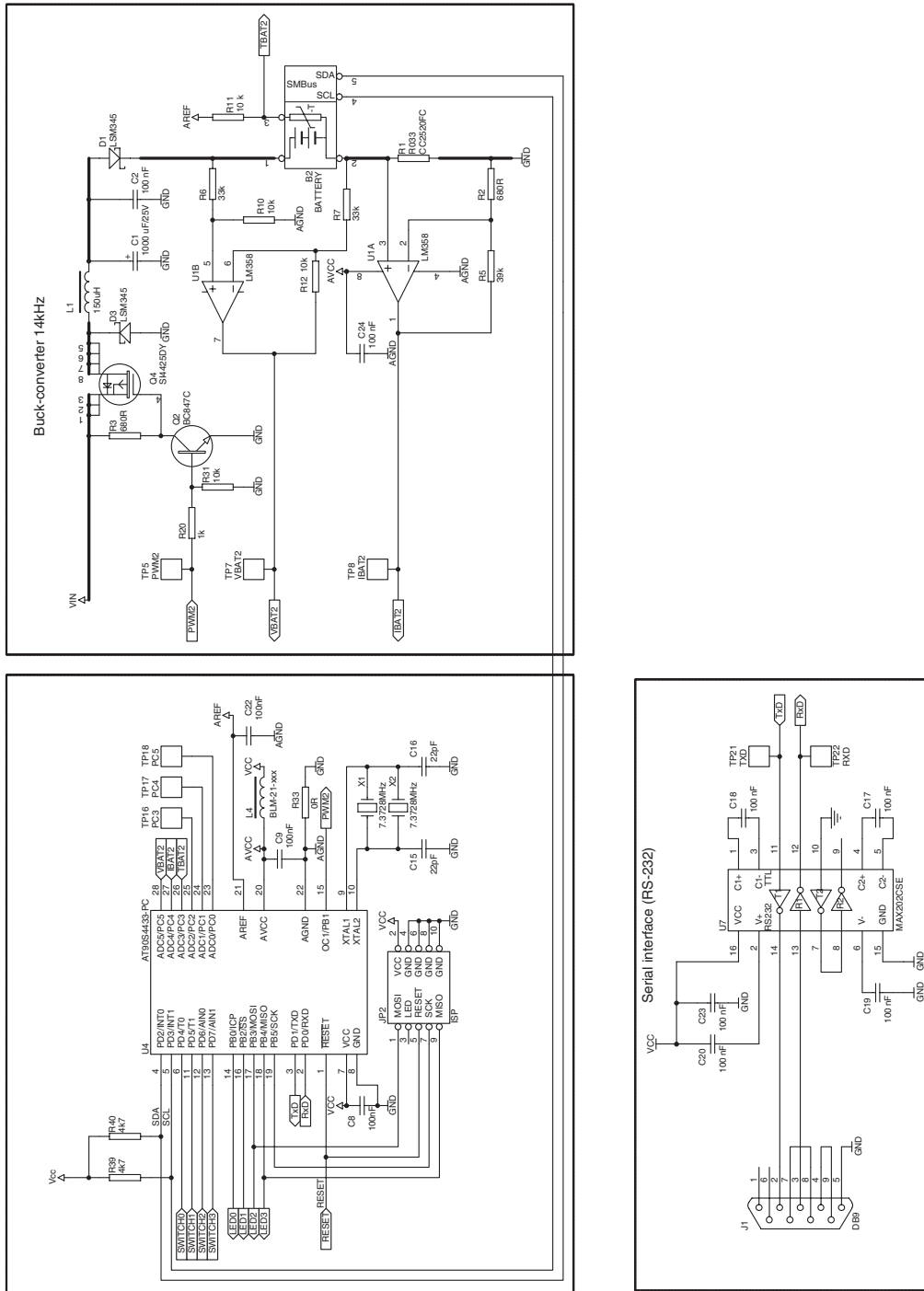

Figure 5-4. AT90S4433 and 14 kHz Buck Converter Schematic



## Appendix 2: Power Supply

The schematic below shows a power supply that supplies both +15V for the battery charger and +5V for the AVR microcontroller.

The power supply unit for the battery charger is built around a TOP224 from Power Integration. The flyback design technique makes a compact and efficient power supply design. The input voltage may vary from 85 VAC to 265 VAC (50 - 60 Hz).

Figure 5-5. Power Supply Schematic

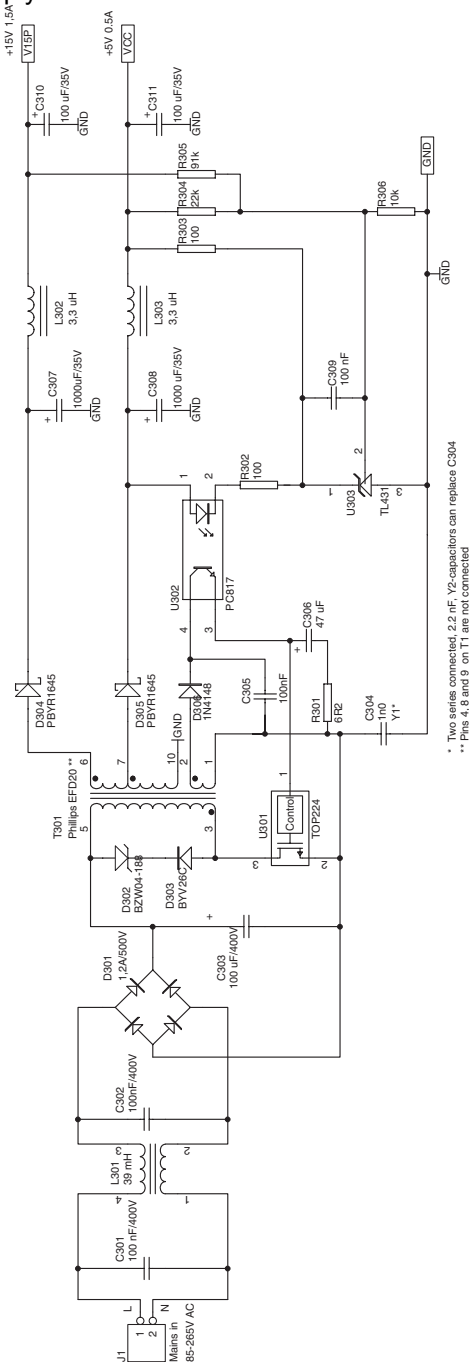

**Table 5-1. Power Supply Part List**

Part	Part Type	Description
R301	6,2Ω	Series resistor for C306 (U301 power supply)
R302	100Ω	Series Resistor for the Opto-coupler
R303	100Ω	Series resistor for the voltage reference
R306	10 kΩ	Feedback circuitry
R304	22 kΩ	Feedback circuitry (5V)
R305	91 kΩ	Feedback circuitry (15V)
C304	1n0/Y1	Y1 capacitor (Can be replaced by 2 * 2.2 nF Y2 capacitors)
C305	100 nF	
C309	100 nF	
C301	100 nF/400V	X Capacitor
C302	100 nF/400V	X Capacitor
C310	100 μF/35V	Post LC filter
C311	100 μF/35V	Post LC filter
C303	100 μF/400V	Primary capacitor
C307	1000 μF/35V	
C308	1000 μF/35V	
L302	3.3 μH	Post LC filter
L303	3,3 μH	Post LC filter
L301	33 mH	Input choke
D301	1.2A/500V	Rectifier Bridge
D302	P6KE200	Clamping Zener diode
D303	BYV26C	Blocking diode for clamping diode.
D304	PBYR1645	Rectifier diode for 15V supply
D305	PBYR1645	Rectifier diode for 5V supply
D306	1N4148	Rectifier diode for bias/U301 power supply
U301	TOP224	Top switch regulator
U302	TL431	Voltage reference
U303	PC817	Opto-coupler
T301	Phillips EFD20	Transformer, see text below for details

The transformer T301 is built around an EFD20 transformer kernel from Philips. The primary winding and the bias winding use AWG26 (0.40 mm) wire gauge. The secondary winding uses AWG20 (0.80 mm). The primary winding and the bias windings are separated from the two secondary windings with insulation tape. The 5V secondary winding is also a part of the 15V winding. It is very important to make the windings according to the directions shown in the schematic.



## Atmel Corporation

2325 Orchard Parkway  
San Jose, CA 95131, USA  
Tel: 1(408) 441-0311  
Fax: 1(408) 487-2600

## Regional Headquarters

### Europe

Atmel Sarl  
Route des Arsenaux 41  
Case Postale 80  
CH-1705 Fribourg  
Switzerland  
Tel: (41) 26-426-5555  
Fax: (41) 26-426-5500

### Asia

Room 1219  
Chinachem Golden Plaza  
77 Mody Road Tsimshatsui  
East Kowloon  
Hong Kong  
Tel: (852) 2721-9778  
Fax: (852) 2722-1369

### Japan

9F, Tonetsu Shinkawa Bldg.  
1-24-8 Shinkawa  
Chuo-ku, Tokyo 104-0033  
Japan  
Tel: (81) 3-3523-3551  
Fax: (81) 3-3523-7581

## Atmel Operations

### Memory

2325 Orchard Parkway  
San Jose, CA 95131, USA  
Tel: 1(408) 441-0311  
Fax: 1(408) 436-4314

### Microcontrollers

2325 Orchard Parkway  
San Jose, CA 95131, USA  
Tel: 1(408) 441-0311  
Fax: 1(408) 436-4314

La Chantrerie  
BP 70602  
44306 Nantes Cedex 3, France  
Tel: (33) 2-40-18-18-18  
Fax: (33) 2-40-18-19-60

### ASIC/ASSP/Smart Cards

Zone Industrielle  
13106 Rousset Cedex, France  
Tel: (33) 4-42-53-60-00  
Fax: (33) 4-42-53-60-01

1150 East Cheyenne Mtn. Blvd.  
Colorado Springs, CO 80906, USA  
Tel: 1(719) 576-3300  
Fax: 1(719) 540-1759

Scottish Enterprise Technology Park  
Maxwell Building  
East Kilbride G75 0QR, Scotland  
Tel: (44) 1355-803-000  
Fax: (44) 1355-242-743

### RF/Automotive

Theresienstrasse 2  
Postfach 3535  
74025 Heilbronn, Germany  
Tel: (49) 71-31-67-0  
Fax: (49) 71-31-67-2340

1150 East Cheyenne Mtn. Blvd.  
Colorado Springs, CO 80906, USA  
Tel: 1(719) 576-3300  
Fax: 1(719) 540-1759

### Biometrics/Imaging/Hi-Rel MPU/ High Speed Converters/RF Datacom

Avenue de Rochepleine  
BP 123  
38521 Saint-Egreve Cedex, France  
Tel: (33) 4-76-58-30-00  
Fax: (33) 4-76-58-34-80

---

### Literature Requests

[www.atmel.com/literature](http://www.atmel.com/literature)

**Disclaimer:** The information in this document is provided in connection with Atmel products. No license, express or implied, by estoppel or otherwise, to any intellectual property right is granted by this document or in connection with the sale of Atmel products. **EXCEPT AS SET FORTH IN ATMEL'S TERMS AND CONDITIONS OF SALE LOCATED ON ATMEL'S WEB SITE, ATMEL ASSUMES NO LIABILITY WHATSOEVER AND DISCLAIMS ANY EXPRESS, IMPLIED OR STATUTORY WARRANTY RELATING TO ITS PRODUCTS INCLUDING, BUT NOT LIMITED TO, THE IMPLIED WARRANTY OF MERCHANTABILITY, FITNESS FOR A PARTICULAR PURPOSE, OR NON-INFRINGEMENT. IN NO EVENT SHALL ATMEL BE LIABLE FOR ANY DIRECT, INDIRECT, CONSEQUENTIAL, PUNITIVE, SPECIAL OR INCIDENTAL DAMAGES (INCLUDING, WITHOUT LIMITATION, DAMAGES FOR LOSS OF PROFITS, BUSINESS INTERRUPTION, OR LOSS OF INFORMATION) ARISING OUT OF THE USE OR INABILITY TO USE THIS DOCUMENT, EVEN IF ATMEL HAS BEEN ADVISED OF THE POSSIBILITY OF SUCH DAMAGES.** Atmel makes no representations or warranties with respect to the accuracy or completeness of the contents of this document and reserves the right to make changes to specifications and product descriptions at any time without notice. Atmel does not make any commitment to update the information contained herein. Unless specifically provided otherwise, Atmel products are not suitable for, and shall not be used in, automotive applications. Atmel's products are not intended, authorized, or warranted for use as components in applications intended to support or sustain life.

© 2006 Atmel Corporation. All rights reserved. ATMEL®, logo and combinations thereof, Everywhere You Are®, AVR®, AVR Studio® and others, are the registered trademarks or trademarks of Atmel Corporation or its subsidiaries. Other terms and product names may be trademarks of others.