AT91RM9200 Microcontroller Schematic Check List

1. Introduction

This application note is a schematic review check list for systems embedding the Atmel® ARM® Thumb®-based AT91RM9200 microcontroller.

It gives requirements concerning the different pin connections that must be considered before starting any new board design and describes the minimum hardware resources required to quickly develop an application with the AT91RM9200. This document does not consider PCB layout constraints.

This application note is not intended to be exhaustive. Its objective is to cover as many configurations of use as possible.

The Check List table has a column reserved for reviewing designers to verify the line item has been checked.



**AT91SAM
ARM-based
Embedded MPU**

Application Note

6323B-ATARM-12-Jan-11



2. Associated Documentation

Before going further into this application note, it is strongly recommended to check the latest documents for the [AT91RM9200](#) Microcontroller on Atmel's Web site.

[Table 2-1](#) gives the associated documentation needed to support full understanding of this application note.

Table 2-1. Associated Documentation

Information	Document Title
User Manual Electrical/Mechanical Characteristics Ordering Information Errata	AT91RM9200 Product Datasheet
Internal architecture of processor ARM/Thumb instruction sets Embedded in-circuit-emulator	ARM9TDMI® Technical Reference Manual ARM920T™ Technical Reference Manual
Evaluation Kit User Guide	AT91RM9200-EK Evaluation Board User Guide

3. Schematic Check List

☑	Signal Name	Pin Connection	Description
	VDDCORE	1.65V to 1.95V Decoupling/Filtering capacitors (100 nF and 10 μ F) ⁽¹⁾⁽²⁾	Powers the device. Decoupling/Filtering capacitors must be added to improve startup stability and reduce source voltage drop.
	VDDIOM ⁽³⁾	3.0V to 3.6V Decoupling/Filtering capacitors (100 nF and 10 μ F) ⁽¹⁾⁽²⁾	Powers the External Bus Interface I/O pads. Decoupling/Filtering capacitors must be added to improve the startup stability and reduce the source voltage drop.
	VDDIOP ⁽³⁾	3.0V to 3.6V Decoupling/Filtering capacitors (100 nF and 10 μ F) ⁽¹⁾⁽²⁾	Powers the Peripheral I/O pads and USB transceivers. Decoupling/Filtering capacitors must be added to improve the startup stability and reduce the source voltage drop.
	VDDOSC	1.65V to 1.95V Decoupling capacitor (100 nF) ⁽¹⁾⁽²⁾	Powers the Main Oscillator and the Slow Clock Oscillator.
	VDDPLL	1.65V to 1.95V Decoupling capacitor (100 nF) ⁽¹⁾⁽²⁾	Powers the PLL cells.
	GND	Ground	GND pins are common to VDDCORE, VDDIOM and VDDIOP pins. GND pins should be connected as shortly as possible to the system ground plane.
	GNDPLL	PLL Ground	GNDPLL pin is provided for VDDPLL pin. GNDPLL pin should be connected as shortly as possible to the system ground plane.
	GNDOSC	Oscillator Ground	GNDOSC pin is provided for VDDOSC pin. GNDOSC pin should be connected as shortly as possible to the system ground plane.

- Notes:
1. These values are given only as a typical example.
 2. Decoupling capacitors must be connected as close as possible to the microcontroller and on each concerned pin.

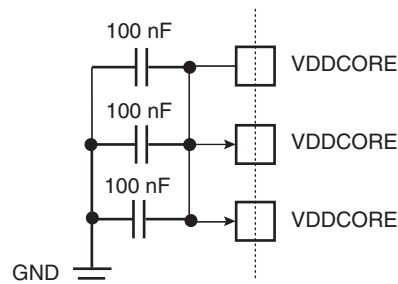

3. The double power supplies VDDIOM and VDDIOP power the device differently when interfacing with memories or with peripherals.

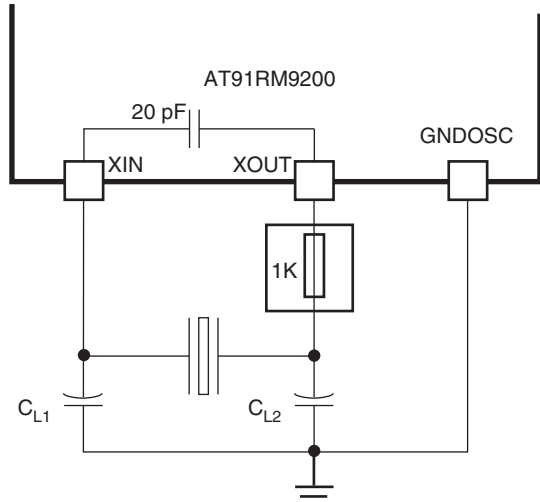
☑	Signal Name	Pin Connection	Description
Clock, Oscillator and PLL			
	<p>XIN XOUT</p> <p>Main Oscillator in Normal Mode</p>	<p>Crystals between 3 and 20 MHz</p> <p>Capacitors on XIN and XOUT (crystal load capacitance dependent)</p> <p>1 KOhm resistor on XOUT only required for crystals with frequencies lower than 8 MHz.</p> <p>Note: XOUT cannot be used to drive another clock input.</p>	<p>Main Oscillator Internal load capacitance: 20 pF Crystal load capacitance to check ($C_{CRYSTAL}$).</p>  <p>Example: for a 18.432 MHz crystal with a load capacitance of $C_{CRYSTAL} = 25$ pF, external capacitors are required: $CL1 = CL2 = 2 \times (25 \text{ pF} - 20 \text{ pF} - C_{board})$ If C_{board} is about 1.5 pF, $CL1 = CL2 = 7$ pF.</p> <p>Refer to the electrical specifications of the AT91RM9200 datasheet.</p>
	<p>XIN XOUT</p> <p>Main Oscillator in Bypass Mode</p>	<p>XIN: external clock source XOUT: can be left unconnected</p>	<p>1.8V square wave signal (VDDOSC) External clock source up to 50 MHz Duty Cycle: 40 to 60%</p> <p>Refer to the electrical specifications of the AT91RM9200 datasheet for C_{IN} and R_{IN} values when using the bypass mode.</p>

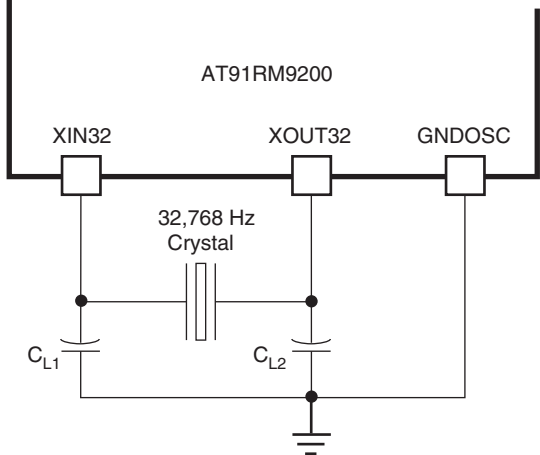
☑	Signal Name	Pin Connection	Description
	<p>XIN32 XOUT32</p> <p>Slow Clock Oscillator</p>	<p>32,768 kHz Crystal</p> <p>External Capacitors: CL1 is between XIN32 and Ground CL2 is between XOUT32 and Ground</p> <p>Note: Wire the 32 kHz crystal as close as possible to the microcontroller. Do not forget to put a guard ring and avoid having any noisy line close to it.</p> <p>XOUT cannot be used to drive another clock input.</p>	<p>Internal parasitic capacitance (including package): 6 pF Supported Crystal with a load capacitance ($C_{CRYSTAL}$) from 6 pF up to 12.5 pF Maximal External Capacitor: $CL1 = CL2 = 2 \times (12.5 - 6 \text{ pF} - C_{board}) = 13 \text{ pF} - 2 \times C_{board}$.</p>  <p>Example: for a 32,768 kHz crystal with a load capacitance of $C_{CRYSTAL} = 9 \text{ pF}$, $C_{board} = 1.5 \text{ pF}$, external capacitors are required: $C_{L1} = C_{L2} = 15 \text{ pF}$.</p> <p>Refer to the electrical specifications of the AT91RM9200 Datasheet</p>

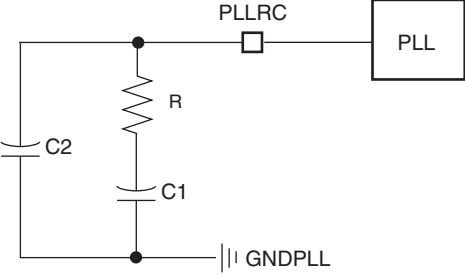
☑	Signal Name	Pin Connection	Description
	PLLRCA PLLRCB	Second-order filter Can be left unconnected if PLL not used.	<p>See the Excel spreadsheet: "ATMEL_PLL_LFT_Filter_CALCULATOR_AT91_xxx.zip" (available in the software files on the Atmel Web site) allowing calculation of the best R-C1-C2 component values for the PLL Loop Back Filter.</p>  <p>PLL filter recommendations:</p> <p>The Fn parameter represents the cutoff frequency at filter level. The higher the frequency, the better the PLL response time. The user should choose the highest frequency for this parameter, but be aware of the two following constraints:</p> <ul style="list-style-type: none"> - Increasing Fn decreases the C1 and C2 values at filter level, whereas the resulting C1, C2 values must have values higher than the stray capacitances of the [package + layout]. - the Fn frequency must be at least 20 times lower than the input frequency. <p>The good damping factor is the one closest to a value of 0.707.</p> <p>$C1 \sim 10xC2$</p> <p>R, C1 and C2 must be placed as close as possible to the pins.</p>
ICE and JTAG⁽⁴⁾			
	TCK	Connected to ICE/JTAG Interface	This pin is a Schmitt trigger input. Internal pull-up resistor.
	TMS		
	TDI		
	TDO		
	RTCK		Output driven up to V_{DDIOP}
	NTRST	To a reset circuitry	NTRST must be driven at power up, even if JTAG port is not used. Note: NTRST can be connected to NRST.

<input checked="" type="checkbox"/>	Signal Name	Pin Connection	Description
	JTAGSEL	Must be tied to GND for normal operation and to VDDIOP to use Boundary scan features	This pin is a Schmitt trigger input. Internal pull-up resistor.
Reset/Test			
	NRST	Must be connected to reset circuitry. The reset delay must cover the 32 Khz start up time (900 ms).	This pin is a Schmitt trigger input. Internal pull-up resistor.
	TST0, TST1	These two pins must be connected to ground for normal operation.	
	PA31/BMS	Application dependent. Must be tied to VDDIOP to boot from Embedded ROM. Must be tied to GND to boot from external memory. (EBI Chip Select 0).	The BMS signal level during reset time boots from embedded ROM or from a 16-bit parallel Flash. This signal must be stable during reset.
PIO			
	PAx PBx PCx	Application dependent.	All PIOs are pulled-up inputs at reset except those which are multiplexed with the Address Bus signals that must be enabled as peripherals: PA30 (A23), PA31 (A24) and PC3 (A25). To reduce power consumption if not used, the concerned PIO can be configured as an output, driven at '0' with internal pull-up disabled.
	PC6/NWAIT	Pull-up (100 KOhm) ⁽¹⁾	A pull-up is mandatory on NWAIT if this pin is not used. If PC6/NWAIT is driven by an external device, the user must ensure that the PC6/NWAIT pin is driven high as soon as the device is powered up.
	PDx ⁽⁵⁾	Application dependent.	ETM features and 2nd USB HOST are available only on PIOD.
Multimedia Card Interface MCI			
	PA28/MCCDA	Pull-up to adjust according to MultiMedia Card specification or SD card Part1 physical layer specification	MCIA Command Line.
	PA8/MCCDB		MCIAB Command Line.
EBI			
	D0-D15 (D16-D31)	Application dependent.	Data bus lines D0 to D15 are pulled-up inputs to V _{VDDIOM} at reset. Note: Data bus lines D16 to D31 for SDRAM access. D16 to D31 are multiplexed with the PIOC controller. PIO input after reset.
	A0-A22 (A23-A25)	Application dependent.	Address Bus (A0 to A25) A0 to A22: Address lines are driven to '0' at reset. A23 to A25 Address bus lines are: - multiplexed with the PIOC controller. - PIO input after reset.

☑	Signal Name	Pin Connection	Description
SMC - SDRAM Controller - CompactFlash® Support			
See “External Bus Interface (EBI) Hardware Interface” on page 10.			
USB Host (UHP)			
	HDP HDPB ⁽⁵⁾	Application dependent. ⁽⁶⁾ Typically, 15 kOhm resistor to GND.	No internal pull-down resistors. To reduce power consumption, if USB Host is not used, connect HDP/HDPB to GND.
	HDMA HDMA ⁽⁵⁾	Application dependent. ⁽⁶⁾ Typically, 15 kOhm resistor to GND.	No internal pull-down resistors. To reduce power consumption, if USB Host is not used, connect HDMA/HDMA to GND.
USB Device (UDP)			
	DDP	Application dependent ⁽⁷⁾	No internal pull-down, no internal pull-up resistors. To reduce power consumption, if USB Device is not used, connect DDP to VDDIOP.
	DDM	Application dependent ⁽⁷⁾	No internal pull-down, pull-up resistors. To reduce power consumption, if USB Device is not used, connect DDM to GND.

4. It is recommended to establish accessibility to a JTAG connector for debug in any case.
5. Available only in the 256-ball RoHS BGA compliant Package.
6. Example of USB Host connection:
A termination serial resistor (R_{EXT}) must be connected to HDP/HDPB and HDMA/HDMA. A recommended resistor value is defined in the electrical specifications of the [AT91RM9200 datasheet](#).

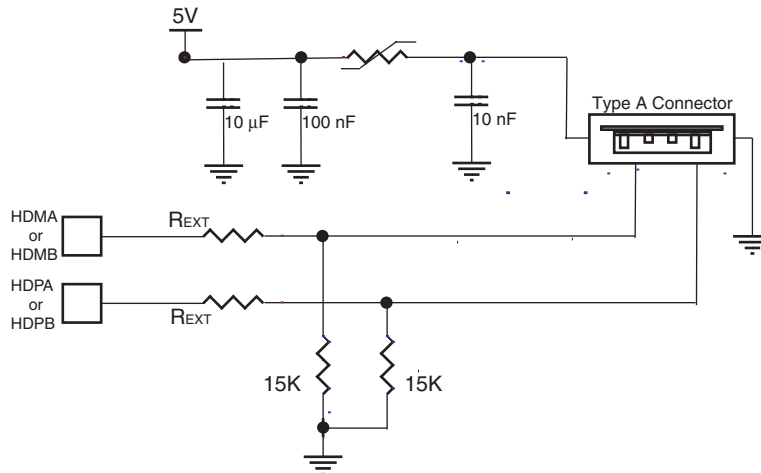

7. Example of USB Device connection:

Pull-up is active by default after reset (required by the boot application). No pull-down: DM is floating when the peripheral is not connected. The application shall monitor VBus and remove the pull-up when the host switches off.

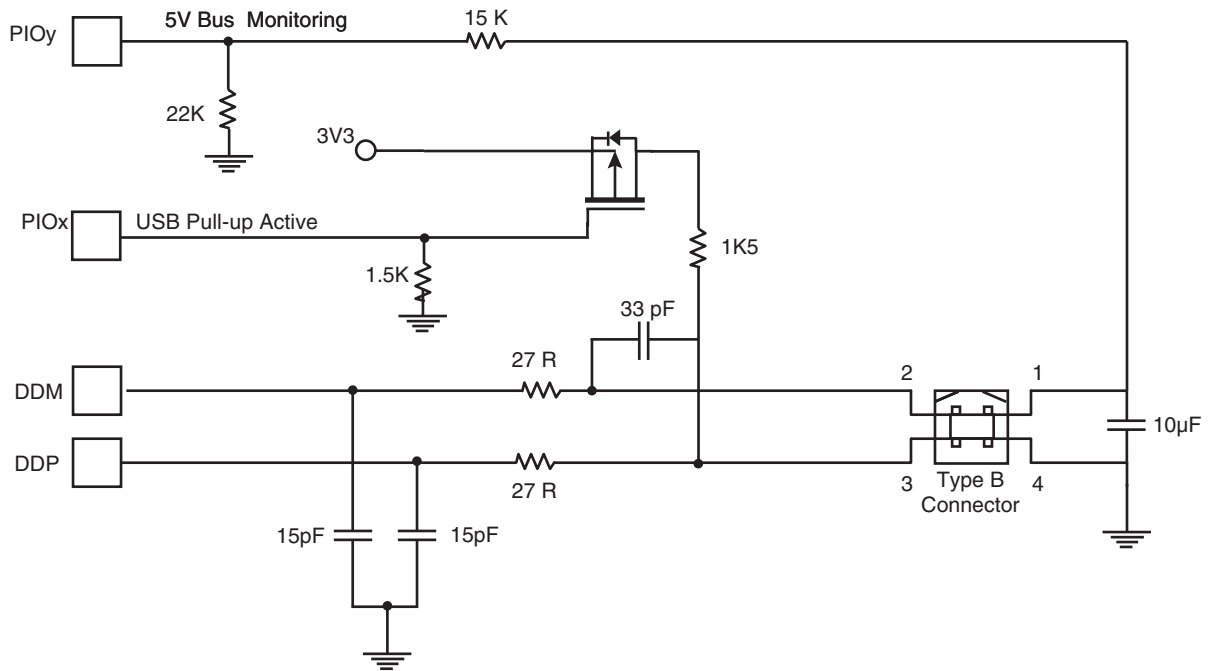

4. External Bus Interface (EBI) Hardware Interface

Table 4-1 details the connections to be applied between the EBI pins and the external devices for each Memory Controller.

Table 4-1. EBI Pins and External Static Devices Connections

Pin	Pins of the Interfaced Device						
	8-bit Static Device	2 x 8-bit Static Devices	16-bit Static Device	Burst Flash Device	SDRAM	Compact Flash	NANDFlash / SmartMedia
Controller	SMC			BFC	SDRAMC	SMC	
D0 - D7	D0 - D7	D0 - D7	D0 - D7	D0 - D7	D0 - D7	D0 - D7	AD0 - AD7
D8 - D15	–	D8 - D15	D8 - D15	D8 - D15	D8 - 15	D8 - 15	–
D16 - D31	–	–	–	–	D16 - D31	–	–
A0/NBS0	A0	–	NLB	–	DQM0	A0	–
A1/NWR2/NBS2	A1	A0	A0	A0	DQM2	A1	–
A2 - A9	A2 - A9	A1 - A8	A1 - A8	A1 - A8	A0 - A7	A2 - A9	–
A10	A10	A9	A9	A9	A8	A10	–
A11	A11	A10	A10	A10	A9	–	–
SDA10	–	–	–	–	A10	–	–
A12	A12	A11	A11	A11	–	–	–
A13 - A14	A13 - A14	A12 - A13	A12 - A13	A12 - A13	A11 - A12	–	–
A15	A15	A14	A14	A14	–	–	–
A16/BA0	A16	A15	A15	A15	BA0	–	–
A17/BA1	A17	A16	A16	A16	BA1	–	–
A18-A20	A18-A20	A17-A19	A17-A19	A17-A19	–	–	–
A21	A21	A20	A20	A20	–	–	CLE
A22	A22	A21	A21	A21	–	REG ⁽³⁾	ALE
A23 - A24	A23 - A24	A22 - A23	A22 - A23	A22 - A23	–	–	–
A25	A25	A24	A24	A24	–	CFRNW ⁽¹⁾	–
NCS0/BFCS	CS	CS	CS	CS	–	–	–
NCS1/SDCS	CS	CS	CS	–	CS	–	–
NCS2	CS	CS	CS	–	–	–	–
NCS3/SMCS	CS	CS	CS	–	–	–	–
NCS4/CFCS	CS	CS	CS	–	–	CFCS ⁽¹⁾	–
NCS5/CFCE1	CS	CS	CS	–	–	CE1	–
NCS6/CFCE2	CS	CS	CS	–	–	CE2	–
NRD/NOE/CFOE	OE	OE	OE	–	–	OE	–
NWR0/NWE/CFWE	WE	WE ⁽⁴⁾	WE	–	–	WE	–
NWR1/NBS1/CFIOR	–	WE ⁽⁴⁾	NUB	–	DQM1	IOR	–
NWR3/NBS3/CFIOW	–	–	–	–	DQM3	IOW	–
BFCK	–	–	–	CK	–	–	–

Table 4-1. EBI Pins and External Static Devices Connections (Continued)

Pin	Pins of the Interfaced Device						
	8-bit Static Device	2 x 8-bit Static Devices	16-bit Static Device	Burst Flash Device	SDRAM	Compact Flash	NANDFlash / SmartMedia
Controller	SMC			BFC	SDRAMC	SMC	
BFAVD	–	–	–	AVD	–	–	–
BFBA/SMWE	–	–	–	BAA	–	–	WE
BFOE	–	–	–	OE	–	–	–
BFRDY/SMOE	–	–	–	RDY	–	–	OE
BFWE	–	–	–	WE	–	–	–
SDCK	–	–	–	–	CLK	–	–
SDCKE	–	–	–	–	CKE	–	–
RAS	–	–	–	–	RAS	–	–
CAS	–	–	–	–	CAS	–	–
SDWE	–	–	–	–	WE	–	–
NWAIT	–	–	–	–	–	WAIT	–
Pxx ⁽²⁾	–	–	–	–	–	CD1 or CD2	–
Pxx ⁽²⁾	–	–	–	–	–	–	CE
Pxx ⁽²⁾	–	–	–	–	–	–	RDY

- Notes:
1. Not directly connected to the CompactFlash slot. Permits the control of the bidirectional buffer between the EBI data bus and the CompactFlash slot.
 2. Any PIO line.
 3. The REG signal of the CompactFlash can be driven by any of the following address bits: A24, A22 to A11.
 4. NWR1 enables upper byte writes. NWR0 enables lower byte writes.

5. AT91RM9200 Restrictions

5.1 Package Restrictions

The AT91RM9200 is available in two packages:

- 208-pin green PQFP, 31.2 x 31.2 mm, 0.5 mm pitch
- 256-ball RoHS compliant BGA, 15 x 15 mm, 0.8 mm ball pitch

The product features of the 256-ball BGA package are extended as compared to the 208-lead PQFP package. The features that are available only with the 256-ball BGA package are:

- Parallel I/O Controller D
- ETM™ port with outputs multiplexed only on the PIO Controller D
- a second USB Host transceiver, opening the Hub capabilities of the embedded USB Host.

5.2 Multiplexing Restrictions

The AT91RM9200 features four PIO controllers:

- PIOA and PIOB
 - Multiplexing I/O lines of the peripheral set
- PIOC
 - Multiplexing the data bus bits 16 to 31
 - Several External Bus Interface control signals.
 - Using PIOC pins increases the number of general-purpose I/O lines available but prevents 32-bit SDRAM memory access
- PIOD
 - Available in the 256-ball BGA package option only, multiplexing outputs of the peripheral set and the ETM port

6. Internal Boot Program Constraints

- PA31/BMS pin must be set to HIGH level to boot on AT91RM9200 internal boot ROM.
- PLLB must be wired:
 - Associated LFT filter must be optimized for a 96 MHz running frequency with an accuracy of $\pm 0.25\%$.

Use PLL Calculator tools (available on www.atmel.com) to estimate the filter.

- A supported crystal is mandatory between XIN and XOUT (see [Table 6-1](#)).
- Supported DataFlash devices (see [Table 6-2](#)) connected on NPCS0 or supported EEPROM devices (see [Table 6-4](#)).

Note: The main oscillator cannot be bypassed.

See the Boot Program section of the [AT91RM9200 datasheet](#) for more details on the boot program.

Table 6-1. Supported Crystals (MHz)

3.0	3.2768	3.6864	3.84	4.0
4.433619	4.9152	5.0	5.24288	6.0
6.144	6.4	6.5536	7.159090	7.3728
7.864320	8.0	9.8304	10.0	11.05920
12.0	12.288	13.56	14.31818	14.7456
16.0	17.734470	18.432	20.0	

Table 6-2. Supported DataFlash Devices

Device	Density	Page Size (bytes)	Number of Pages
AT45DB011	1 Mbit	264	512
AT45DB021	2 Mbits	264	1024
AT45DB041	4 Mbits	264	2048
AT45DB081	8 Mbits	264	4096
AT45DB161	16 Mbits	528	4096
AT45DB321	32 Mbits	528	8192
AT45DB642	64 Mbits	1056	8192

The DataFlash must be connected to NPCS0 of the SPI.

Table 6-3. Supported EEPROM Devices

Device	Size	Organization
AT24C16A	16 Kbits	16 bytes page write
AT24C164	16 Kbits	16 bytes page write
AT24C32	32 Kbits	32 bytes page write
AT24C64	64 Kbits	32 bytes page write
AT24C128	128 Mbits	64 bytes page write
AT24C256	256 Kbits	64 bytes page write
AT24C512	512 Kbits	128 bytes page write

Generally, serial EEPROMs have no identification code. The bootloader checks for an acknowledgment on the first read. The device address on the two-wire bus must be 0x0. The bootloader supports the devices listed in [Table 6-3](#).

6.1 Hardware Limitations of the Internal Boot Program

The SPI and TWI drivers use several PIOs in alternate functions to communicate with devices. Care must be taken when these PIOs are used by the application. The devices connected could be unintentionally driven at boot time, and electrical conflicts between SPI or TWI output pins and the connected devices may appear.

[Table 6-4](#) contains a list of pins that are driven during the Boot Program execution. These pins are driven during the boot sequence for a period of about 6 ms if no correct boot program is found. The download through the TWI takes about 5 seconds for 64 Kbytes due to the TWI bit rate (100 Kbits/s).



For the DataFlash driven by the SPCK signal at 12 MHz, the time required to download 64 Kbytes is reduced to 66 ms.

Table 6-4. Pins Driven during Internal Boot Program Execution

Peripheral	Pin	PIO Line
SPI	MOSI	PA1
SPI	SPCK	PA0
SPI	NPCS0	PA3
TWI	TWD	PA25
TWI	TWCK	PA26
DBGU	DRXD	PA9
DBGU	DTXD	PA10

The AT91RM9200 Boot program supports serial communication via the DBGU or DFU protocol via the USB Device Port. The USB pull-up must be active by default after reset.

7. External Boot Constraints

- PA31/BMS pin must be set to LOW level.
- Boot from an external 16-bit parallel Flash connected on NCS0.
- All initialization (PLL,SDRAM, SMC, etc.) is user dependent.

Revision History

Doc. Rev	Comments	Change Request Ref.
6323B	VDDOSC description edited in Section 3. "Schematic Check List" .	7324
	Some typos fixed.	rfo
6323A	First issue	





Headquarters

Atmel Corporation
2325 Orchard Parkway
San Jose, CA 95131
USA
Tel: 1(408) 441-0311
Fax: 1(408) 487-2600

International

Atmel Asia
Unit 1-5 & 16, 19/F
BEA Tower, Millennium City 5
418 Kwun Tong Road
Kwun Tong, Kowloon
Hong Kong
Tel: (852) 2245-6100
Fax: (852) 2722-1369

Atmel Europe
Le Krebs
8, Rue Jean-Pierre Timbaud
BP 309
78054 Saint-Quentin-en-
Yvelines Cedex
France
Tel: (33) 1-30-60-70-00
Fax: (33) 1-30-60-71-11

Atmel Japan
9F, Tonetsu Shinkawa Bldg.
1-24-8 Shinkawa
Chuo-ku, Tokyo 104-0033
Japan
Tel: (81) 3-3523-3551
Fax: (81) 3-3523-7581

Product Contact

Web Site
www.atmel.com
www.atmel.com/AT91SAM

Technical Support
[AT91SAM Support](mailto:AT91SAM_Support@atmel.com)
[Atmel technical support](mailto:Atmel_technical_support@atmel.com)

Sales Contacts
www.atmel.com/contacts/

Literature Requests
www.atmel.com/literature

Disclaimer: The information in this document is provided in connection with Atmel products. No license, express or implied, by estoppel or otherwise, to any intellectual property right is granted by this document or in connection with the sale of Atmel products. **EXCEPT AS SET FORTH IN ATMEL'S TERMS AND CONDITIONS OF SALE LOCATED ON ATMEL'S WEB SITE, ATMEL ASSUMES NO LIABILITY WHATSOEVER AND DISCLAIMS ANY EXPRESS, IMPLIED OR STATUTORY WARRANTY RELATING TO ITS PRODUCTS INCLUDING, BUT NOT LIMITED TO, THE IMPLIED WARRANTY OF MERCHANTABILITY, FITNESS FOR A PARTICULAR PURPOSE, OR NON-INFRINGEMENT. IN NO EVENT SHALL ATMEL BE LIABLE FOR ANY DIRECT, INDIRECT, CONSEQUENTIAL, PUNITIVE, SPECIAL OR INCIDENTAL DAMAGES (INCLUDING, WITHOUT LIMITATION, DAMAGES FOR LOSS OF PROFITS, BUSINESS INTERRUPTION, OR LOSS OF INFORMATION) ARISING OUT OF THE USE OR INABILITY TO USE THIS DOCUMENT, EVEN IF ATMEL HAS BEEN ADVISED OF THE POSSIBILITY OF SUCH DAMAGES.** Atmel makes no representations or warranties with respect to the accuracy or completeness of the contents of this document and reserves the right to make changes to specifications and product descriptions at any time without notice. Atmel does not make any commitment to update the information contained herein. Unless specifically provided otherwise, Atmel products are not suitable for, and shall not be used in, automotive applications. Atmel's products are not intended, authorized, or warranted for use as components in applications intended to support or sustain life.



© 2011 Atmel Corporation. All rights reserved. Atmel®, Atmel logo and combinations thereof, DataFlash®, SAM-BA® and others are registered trademarks or trademarks of Atmel Corporation or its subsidiaries. ARM®, the ARM Powered® logo, Thumb® and others are registered trademarks or trademarks of ARM Ltd. Other terms and product names may be the trademarks of others.