

## Features

- 1.5 Gbps Bi-directional Transceiver
  - Compliant with Serial ATA Gen1 Revision 1.0a Specification
- Low Power Operation
  - 75 mW per Channel Nominal
- Key Blocks Include
  - Integrated OOB Processor
  - K28.5 COMMA Detection
  - Digital Clock and Data Recovery (CDR) with Digital Equalization
  - Spread Spectrum Clocking
  - Optional 8B/10B Encoder and Decoder
- Parallel I/O
  - Synchronous 8-bit/10-bit Parallel Interface @ 150 MHz
- Serial I/O
  - Programmable Pre-emphasis
  - Support for Spread Spectrum Clocking
  - Integrated 100Ω Matched Differential Termination
  - AC and DC Coupling Support
- Test Features
  - Far-end and Near-end Loopback Support
  - At Speed BIST

## Overview

The AT78C5090 is a 2-channel SATA PHY supporting Gen 1 speeds of 1.5 Gbps. The IP has been designed based on the requirements stated in the Serial ATA Standard, Rev 1.0a, Jan 2003.

On the transmit path, parallel data is registered, passed through a transmit FIFO to compensate for phase differences between the link and PHY clocks, 8B/10B encoded and then passed out via a high speed serializer using a spread spectrum clock. Built-in flexibility permits bypassing the encoding block in addition to optionally disabling the spread spectrum clocking. The user can control the transmit buffer output swing and pre-emphasis levels via direct input signals.

On the receive path, the AT78C5090 performs the serial-to-parallel conversion, using a high bandwidth clock and data recovery (CDR) block. The recovered data is then passed through a comma alignment block and an optional 8B/10B decode block before being passed to the phyCtrl layer via a parallel interface. This interface is synchronous to the recovered clock.

The PHY core has an out of band (OOB) processor. As specified by the Serial ATA standard, three out of band (OOB) signals are used/detected by the PHY, namely COMRESET, COMINIT, and COMWAKE. Each of these signals are indicated by a number of bursts of four ALIGN primitives followed by defined idle periods during which the differential voltage on the serial line is null. OOB signals are observed by detecting the temporal spacing between adjacent bursts of activity.

Test functions including BIST, scan, parallel and serial loopback modes are configured and controlled by the use of direct input signals. Similarly, error/status bits are indicated through direct output signals such as bistErr.



## 2-channel Serial ATA PHY

## AT78C5090

## Summary

3526BS-NETST-4/05



Note: This is a summary document. A complete document is available under NDA. For more information, please contact your local Atmel sales office.

# Block Diagram<sup>(1)</sup>

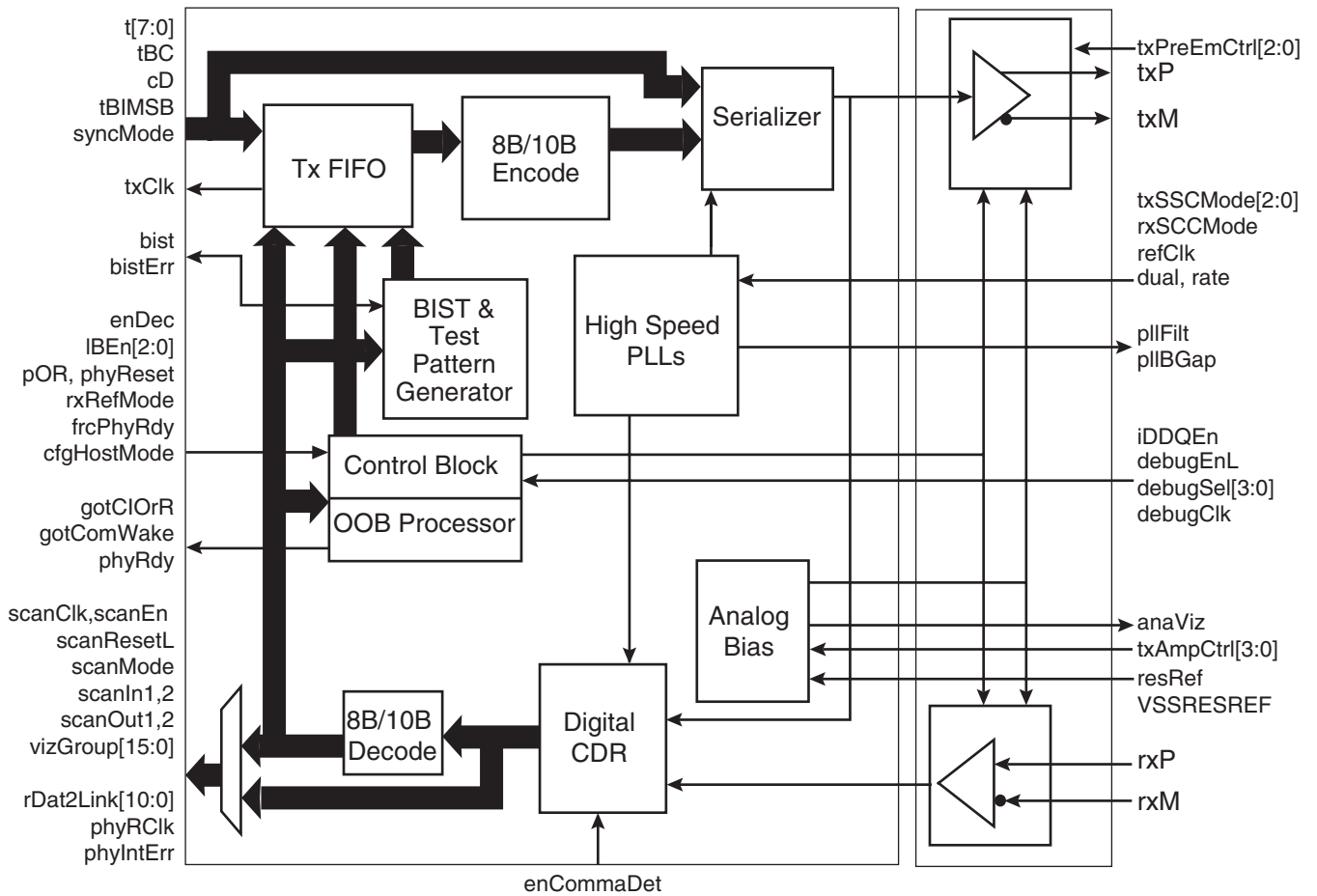

Note: 1. The block diagram only shows one channel.



## Atmel Corporation

2325 Orchard Parkway  
San Jose, CA 95131, USA  
Tel: 1(408) 441-0311  
Fax: 1(408) 487-2600

## Regional Headquarters

### Europe

Atmel Sarl  
Route des Arsenalux 41  
Case Postale 80  
CH-1705 Fribourg  
Switzerland  
Tel: (41) 26-426-5555  
Fax: (41) 26-426-5500

### Asia

Room 1219  
Chinachem Golden Plaza  
77 Mody Road Tsimshatsui  
East Kowloon  
Hong Kong  
Tel: (852) 2721-9778  
Fax: (852) 2722-1369

### Japan

9F, Tonetsu Shinkawa Bldg.  
1-24-8 Shinkawa  
Chuo-ku, Tokyo 104-0033  
Japan  
Tel: (81) 3-3523-3551  
Fax: (81) 3-3523-7581

## Atmel Operations

### Memory

2325 Orchard Parkway  
San Jose, CA 95131, USA  
Tel: 1(408) 441-0311  
Fax: 1(408) 436-4314

### Microcontrollers

2325 Orchard Parkway  
San Jose, CA 95131, USA  
Tel: 1(408) 441-0311  
Fax: 1(408) 436-4314

La Chantrerie  
BP 70602  
44306 Nantes Cedex 3, France  
Tel: (33) 2-40-18-18-18  
Fax: (33) 2-40-18-19-60

### ASIC/ASSP/Smart Cards

Zone Industrielle  
13106 Rousset Cedex, France  
Tel: (33) 4-42-53-60-00  
Fax: (33) 4-42-53-60-01

1150 East Cheyenne Mtn. Blvd.  
Colorado Springs, CO 80906, USA  
Tel: 1(719) 576-3300  
Fax: 1(719) 540-1759

Scottish Enterprise Technology Park  
Maxwell Building  
East Kilbride G75 0QR, Scotland  
Tel: (44) 1355-803-000  
Fax: (44) 1355-242-743

### RF/Automotive

Theresienstrasse 2  
Postfach 3535  
74025 Heilbronn, Germany  
Tel: (49) 71-31-67-0  
Fax: (49) 71-31-67-2340

1150 East Cheyenne Mtn. Blvd.  
Colorado Springs, CO 80906, USA  
Tel: 1(719) 576-3300  
Fax: 1(719) 540-1759

### Biometrics/Imaging/Hi-Rel MPU/ High Speed Converters/RF Datacom

Avenue de Rochepleine  
BP 123  
38521 Saint-Egreve Cedex, France  
Tel: (33) 4-76-58-30-00  
Fax: (33) 4-76-58-34-80

---

## Literature Requests

[www.atmel.com/literature](http://www.atmel.com/literature)

**Disclaimer:** The information in this document is provided in connection with Atmel products. No license, express or implied, by estoppel or otherwise, to any intellectual property right is granted by this document or in connection with the sale of Atmel products. **EXCEPT AS SET FORTH IN ATMEL'S TERMS AND CONDITIONS OF SALE LOCATED ON ATMEL'S WEB SITE, ATMEL ASSUMES NO LIABILITY WHATSOEVER AND DISCLAIMS ANY EXPRESS, IMPLIED OR STATUTORY WARRANTY RELATING TO ITS PRODUCTS INCLUDING, BUT NOT LIMITED TO, THE IMPLIED WARRANTY OF MERCHANTABILITY, FITNESS FOR A PARTICULAR PURPOSE, OR NON-INFRINGEMENT. IN NO EVENT SHALL ATMEL BE LIABLE FOR ANY DIRECT, INDIRECT, CONSEQUENTIAL, PUNITIVE, SPECIAL OR INCIDENTAL DAMAGES (INCLUDING, WITHOUT LIMITATION, DAMAGES FOR LOSS OF PROFITS, BUSINESS INTERRUPTION, OR LOSS OF INFORMATION) ARISING OUT OF THE USE OR INABILITY TO USE THIS DOCUMENT, EVEN IF ATMEL HAS BEEN ADVISED OF THE POSSIBILITY OF SUCH DAMAGES.** Atmel makes no representations or warranties with respect to the accuracy or completeness of the contents of this document and reserves the right to make changes to specifications and product descriptions at any time without notice. Atmel does not make any commitment to update the information contained herein. Atmel's products are not intended, authorized, or warranted for use as components in applications intended to support or sustain life.

© Atmel Corporation 2005. All rights reserved. Atmel®, logo and combinations thereof, Everywhere You Are® and others are registered trademarks, and others are the trademarks of Atmel Corporation or its subsidiaries. Other terms and product names may be trademarks of others.



Printed on recycled paper.

3526BS-NETST-4/05