

1. Introduction

The development board for the ATA6661/ATA6662 (ATA6661-EK, ATA6662-EK) is designed to give designers a quick start with these ICs and for the prototyping and testing of new designs. The ATA6661/ATA6662 is a fully integrated LIN transceiver complying with the LIN 2.0 specification. The ATA6661 and ATA6662 are pin and function compatible, but the ATA6662 has improved EMC behavior.

The IC interfaces between the LIN protocol handler and the physical layer, and is designed to handle the low-speed data communication in vehicles, for example, in convenience electronics. Improved slope control on the LIN bus ensures secure data communication up to 20 Kbaud with a RC oscillator for the protocol handling. The bus output is capable of withstanding high voltage and complies with the 42V power network requirements. Sleep mode guarantees minimal current consumption.

This document has been developed to give the user a quick start with the development board of the ATA6661/ATA6662. For more detailed information about the use of the ATA6661/ATA6662 itself, please refer to the corresponding datasheet.

Figure 1-1. ATA6661/ATA6662 Development Board

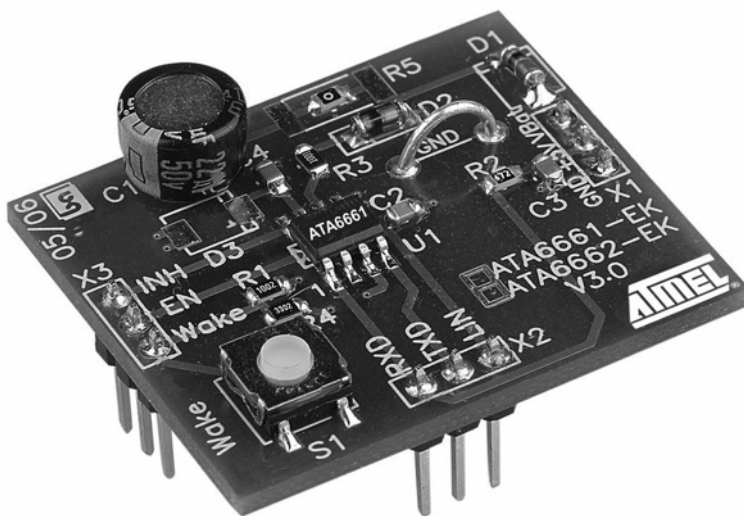

1.1 Development Board Features

The development board for the ATA6661/ATA6662 supports the following features:

- Includes All Components Necessary for ATA6661/ATA6662 Operation
- All Pins Are Easily Accessible
- Can Be Used for Master or Slave Operation
- Wake-up Pulse via an On-board Switch
- 24V Application Can be Built up on the Board



ATA6661/ ATA6662 Development Board

Application Note

1.2 Quick Start

The development board for the ATA6661/ATA6662 is shipped with all components necessary to start with the development of a LIN slave node immediately.

Connecting an external 12V DC power supply between the terminals VBAT and GND puts the IC in the pre-normal mode. In this mode, the inhibit pin INH will be switched to the VS level in order to enable an external voltage regulator (not included on the board). The LIN pin is in the recessive state.

Please note that the communication is still inactive during pre-normal mode.

In order to communicate via the LIN bus interface, you have to switch to normal mode by applying 5V at pin EN.

As RXD is an open-drain output, the necessary pull-up resistor can be activated by applying a +5V DC voltage, for example at pin +5V on the board.

2. Hardware Description

In the following sections only the normal operating conditions will be described. For detailed information concerning the mentioned features, refer to the corresponding datasheet.

2.1 Power Supply (VBAT, +5V and GND)

The development board requires an external 5.7V to 18V DC power supply between the terminals VBAT and GND. The input circuit is protected against inverse-polarity with the protection diode D1, so that there is normally a difference between the VBAT and VS level of approximately 0.7V.

The DC voltage at pin +5V is only needed when the pull-up resistor for the pin RXD is to be activated.

2.2 LIN Interface (LIN, TXD and RXD)

2.2.1 Bus Pin (LIN)

A low-side driver with internal current limitation, thermal shutdown, and an internal pull-up resistor in compliance with LIN spec 2.0 is implemented. LIN receiver thresholds are compatible to the LIN protocol specification.

On the board at the LIN pin there is a 220-pF capacitor to ground. Additionally, the two extra components (diode D2 (LL4148) in series with resistor R3 (1 k Ω)) necessary to use the development board for a LIN master application have designated placeholders for convenient mounting.

2.2.2 Input Pin (TXD)

This pin is the microcontroller interface to control the state of the LIN output. TXD must be pulled to ground in order to have the LIN bus low. If TXD is high, the LIN output transistor is turned off and the bus is in the recessive state, pulled up by the internal resistor. If TXD is low, the LIN output transistor is turned on and the bus is in the dominant state. An internal timer prevents the bus line from being driven permanently in the dominant state. If TXD is forced to low longer than $t_{DOM} > 20$ ms, the LIN bus driver is switched to the recessive state.

2.2.3 Output Pin (RXD)

This pin reports the state of the LIN bus to the microcontroller. LIN high (recessive state) is reported by a high level at RXD, LIN low (dominant state) is reported by a low level at RXD. The output is short-circuit protected.

Please note that the ATA6661/ATA6662 has to be in normal mode in order to have the communication via LIN enabled.

2.3 System Control (EN, INH and WAKE)

2.3.1 Enable Pin (EN)

This pin controls the operation mode of the interface. If EN = 1 the interface is in normal mode, with transmission paths from TXD to LIN and from LIN to RXD both active. If EN = 0 the device is switched to sleep mode and no transmission is possible.

2.3.2 Inhibit Pin (INH)

This pin is used to control an external switchable voltage regulator having an inhibit input. The inhibit pin is a high-side switch structure connected to VS. If the device is in normal mode, the inhibit high-side switch is turned on and the external voltage regulator is activated. When the device is in sleep mode, the inhibit switch is turned off and the external voltage regulator will be disabled.

2.3.3 Wake Pin (WAKE)

This pin is a high voltage input used to wake the device up from sleep mode. It is usually connected to an external switch in order to generate a local wake-up.

If no local wake-up is needed in the application, the WAKE pin should be connected directly to the VS pin.

3. Schematic and Layout of the ATA6661/ATA6662 Development Board

Figure 3-1. Schematic of the Development Board for the ATA6661/ATA6662

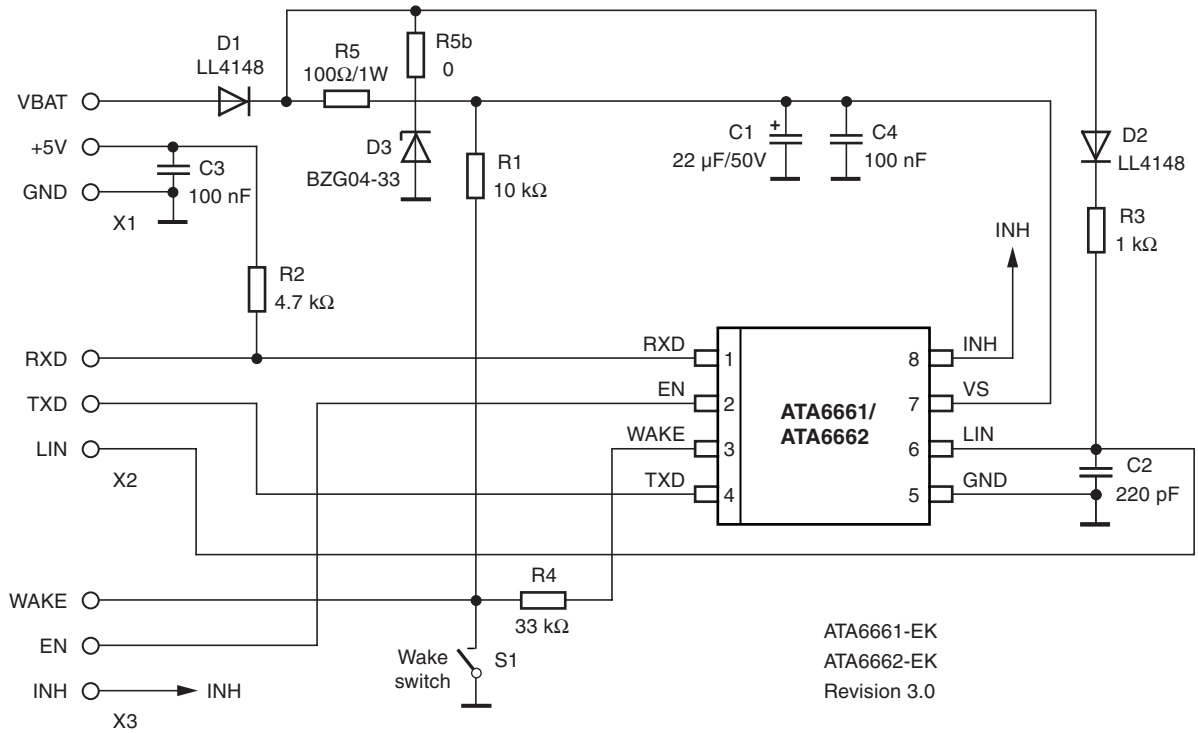

- Notes:
1. D2 and R3 are only necessary for a master node.
 2. R5 and D3 are only used in 24V applications. They guarantee that the supply voltage VS never exceeds the maximum rating of $VS_{max} = 40V$. Refer to the corresponding application note of the ATA6661 for further information.

ATA6661/ATA6662 Development Board

Figure 3-2. Board Component Placement; Top Side, Top View

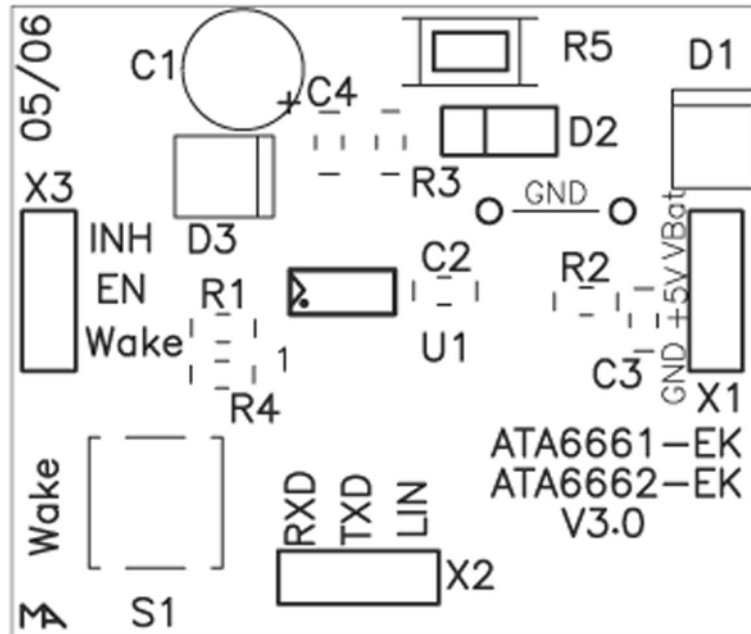

Figure 3-3. ATA6661/ATA6662 Development Board; Top Side, Top View

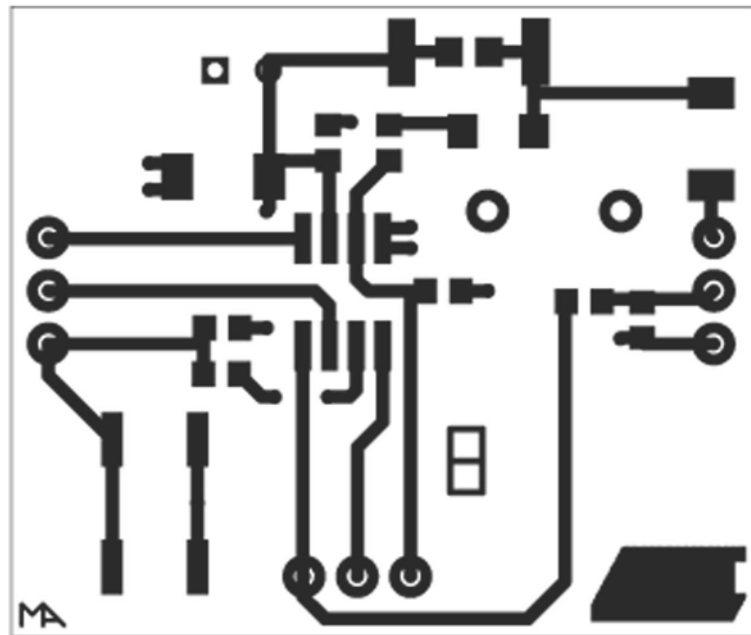
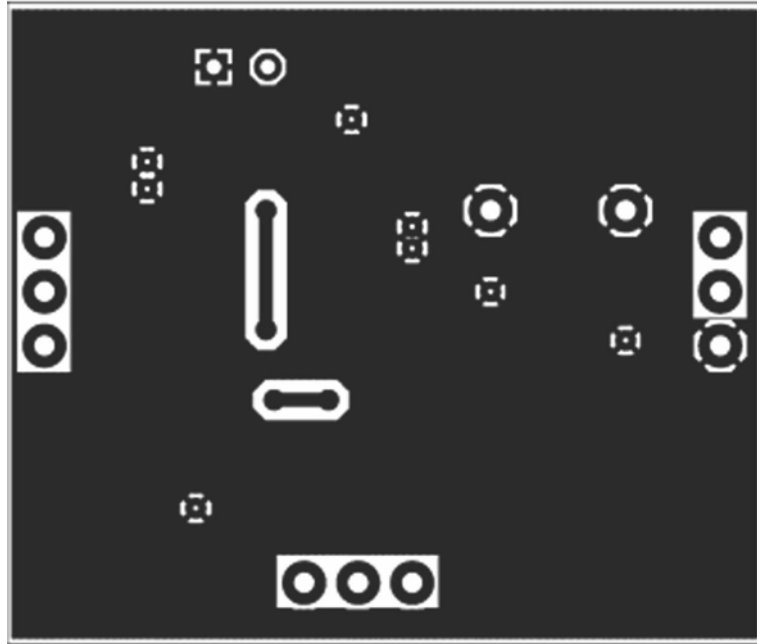

Figure 3-4. ATA6661/ATA6662 Development Board; Bottom Side, Top View (as if PCB Were Transparent)





Atmel Corporation

2325 Orchard Parkway
San Jose, CA 95131, USA
Tel: 1(408) 441-0311
Fax: 1(408) 487-2600

Regional Headquarters

Europe

Atmel Sarl
Route des Arsenaux 41
Case Postale 80
CH-1705 Fribourg
Switzerland
Tel: (41) 26-426-5555
Fax: (41) 26-426-5500

Asia

Room 1219
Chinachem Golden Plaza
77 Mody Road Tsimshatsui
East Kowloon
Hong Kong
Tel: (852) 2721-9778
Fax: (852) 2722-1369

Japan

9F, Tonetsu Shinkawa Bldg.
1-24-8 Shinkawa
Chuo-ku, Tokyo 104-0033
Japan
Tel: (81) 3-3523-3551
Fax: (81) 3-3523-7581

Atmel Operations

Memory

2325 Orchard Parkway
San Jose, CA 95131, USA
Tel: 1(408) 441-0311
Fax: 1(408) 436-4314

Microcontrollers

2325 Orchard Parkway
San Jose, CA 95131, USA
Tel: 1(408) 441-0311
Fax: 1(408) 436-4314

La Chantrerie
BP 70602
44306 Nantes Cedex 3, France
Tel: (33) 2-40-18-18-18
Fax: (33) 2-40-18-19-60

ASIC/ASSP/Smart Cards

Zone Industrielle
13106 Rousset Cedex, France
Tel: (33) 4-42-53-60-00
Fax: (33) 4-42-53-60-01

1150 East Cheyenne Mtn. Blvd.
Colorado Springs, CO 80906, USA
Tel: 1(719) 576-3300
Fax: 1(719) 540-1759

Scottish Enterprise Technology Park
Maxwell Building
East Kilbride G75 0QR, Scotland
Tel: (44) 1355-803-000
Fax: (44) 1355-242-743

RF/Automotive

Theresienstrasse 2
Postfach 3535
74025 Heilbronn, Germany
Tel: (49) 71-31-67-0
Fax: (49) 71-31-67-2340

1150 East Cheyenne Mtn. Blvd.
Colorado Springs, CO 80906, USA
Tel: 1(719) 576-3300
Fax: 1(719) 540-1759

Biometrics

Avenue de Rochepleine
BP 123
38521 Saint-Egreve Cedex, France
Tel: (33) 4-76-58-47-50
Fax: (33) 4-76-58-47-60

Literature Requests

www.atmel.com/literature

Disclaimer: The information in this document is provided in connection with Atmel products. No license, express or implied, by estoppel or otherwise, to any intellectual property right is granted by this document or in connection with the sale of Atmel products. **EXCEPT AS SET FORTH IN ATMEL'S TERMS AND CONDITIONS OF SALE LOCATED ON ATMEL'S WEB SITE, ATMEL ASSUMES NO LIABILITY WHATSOEVER AND DISCLAIMS ANY EXPRESS, IMPLIED OR STATUTORY WARRANTY RELATING TO ITS PRODUCTS INCLUDING, BUT NOT LIMITED TO, THE IMPLIED WARRANTY OF MERCHANTABILITY, FITNESS FOR A PARTICULAR PURPOSE, OR NON-INFRINGEMENT. IN NO EVENT SHALL ATMEL BE LIABLE FOR ANY DIRECT, INDIRECT, CONSEQUENTIAL, PUNITIVE, SPECIAL OR INCIDENTAL DAMAGES (INCLUDING, WITHOUT LIMITATION, DAMAGES FOR LOSS OF PROFITS, BUSINESS INTERRUPTION, OR LOSS OF INFORMATION) ARISING OUT OF THE USE OR INABILITY TO USE THIS DOCUMENT, EVEN IF ATMEL HAS BEEN ADVISED OF THE POSSIBILITY OF SUCH DAMAGES.** Atmel makes no representations or warranties with respect to the accuracy or completeness of the contents of this document and reserves the right to make changes to specifications and product descriptions at any time without notice. Atmel does not make any commitment to update the information contained herein. Unless specifically provided otherwise, Atmel products are not suitable for, and shall not be used in, automotive applications. Atmel's products are not intended, authorized, or warranted for use as components in applications intended to support or sustain life.

© 2007 Atmel Corporation. All rights reserved. Atmel®, logo and combinations thereof, Everywhere You Are® and others are registered trademarks or trademarks of Atmel Corporation or its subsidiaries. Other terms and product names may be trademarks of others.